

W/D

S229900

GF# 327407-R 1 129  
AMERICAN TITLE COMPANY/UNIT 581  
206

SPECIAL WARRANTY DEED

Date 11-21-96 12/03/96 200312149 5229900 \$145.00

Grantor FRIENDSWOOD DEVELOPMENT COMPANY 510-00-2289

Grantor's Mailing Address  
P. O. Box 3486  
Houston, Texas 77253-3486

Grantee KINGS HARBOUR JV63

5) *lll*

Grantee's Mailing Address  
1907 Carriage Creek Lane  
Friendswood, Texas 77546

Consideration Cash and other good and valuable consideration, receipt and sufficiency of which are hereby acknowledged.

145  
X

Property The surface estate of the land containing 63.568 acres, more or less, and being further described by metes and bounds in Exhibit "A" attached hereto and made a part hereof for all purposes.

Reservations from and Exceptions to Conveyance and Warranty

1. This conveyance is subject to all matters of record in Harris County, Texas, enforceable against the Property on this date and all laws, regulations and restrictions, including building and zoning ordinances, if any, of municipal or other governmental authorities applicable to and enforceable against the above-described Property.
2. Taxes and special assessments are prorated as of this date, and Grantee assumes and agrees to pay same.
3. All rights, obligations and other matters emanating from and existing by reason of the creation, establishment, maintenance, and operation of the Harris County Water District (Utility District No. 262), within whose jurisdiction the Property is located in its entirety.
4. Declaration executed by Friendswood Development Company running with the Property recorded under Clerk's File No. N467646, of the Real Property Records of Harris County, Texas, reference to which instrument is here made for all purposes. Annexation of a certain parcel into the Kings Crossing Trail Association shall be effective on the first day of the month following the recordation of a subdivision plat of that certain parcel. It is the obligation of the Purchaser to supply a copy of the recorded subdivision plat to Seller or assigns within ten (10) days of the date of recordation.

510-00-2290

5. Grantor reserves and excepts for itself, its successors and assigns, and its predecessors in title in accordance with their respective interests of record, all oil, gas and other minerals on, in and under the above-described Property.
6. All easements and restrictions provided for in the map or plat referred to in the description of the Property.
7. The Property is and shall be subject to those covenants, conditions, and restrictions contained in that instrument entitled "Protective Covenants" attached hereto as Exhibit "B" and made a part hereof for all purposes to the same extent as if fully set out in length herein.
8. Grantor excepts herefrom and reserves unto itself, its successors and assigns, and its predecessors in title in accordance with its respective interests of record, all oil, gas and other minerals in, on or under the land conveyed hereby, but Grantor on its own behalf and in exercise of its executive leasing rights does hereby release and relinquish its right to use the surface of said land for exploring and drilling for and producing and mining such minerals; provided that Grantor shall have and hereby reserve the right to drill under and through subsurface of land below the depth of one hundred feet (100') from the surface thereof by a well or wells located on the surface of land outside the boundaries of the land conveyed hereby and the right to pool and combine such Property with other land for the purpose of exploring and drilling for and producing and mining such minerals.
9. Grantee and Grantee's successors, assigns and tenants shall maintain the Property in a sanitary and attractive manner equivalent to or better than the general maintenance standard of the Kingwood area and shall not permit the accumulation of or incineration of vegetation, garbage, trash or rubbish of any kind thereon except that vegetation shall be allowed to live and grow naturally in lieu of planned landscaping on the Property or any individual tract or reserve as shown on a plat thereof, until development and construction has been completed on such tract or reserve. In the event of default on the part of Grantee, Grantee's successors, assigns, and tenants in observing such requirements, and continuing after ten (10) days written notice thereof, Grantor, their successors and assigns, may without liability to the owner or occupant, in trespass or otherwise, enter upon the land and premises, cut, or cause to be removed such vegetation, garbage, trash or rubbish or do any other thing necessary to secure the land and premise in a neat, attractive, and sanitary condition, and may charge the owner or occupant for the reasonable cost of such action. Grantee or Grantee's tenants agree to pay Grantors or their assigns within thirty (30) days, or the amount of such charge shall constitute a lien upon the land enforceable as any other lien, but shall be subordinate to the lien of any mortgage.

Grantor, for the consideration and subject to the Reservations from and Exceptions to Conveyance and Warranty, grants, sells, and conveys to Grantee the Property, together with all and singular the rights and appurtenances thereto in any wise belonging, to have and hold it to Grantee and Grantee's successors and assigns forever. Grantor binds

510-00-2291

Grantor and Grantor's successors and assigns against every person whomsoever, lawfully claiming or to claim the same or any part thereof, except as to the Reservations from and Exceptions to Conveyance and Warranty, when the claim is by, through, or under Grantor but not otherwise.

The reservations, covenants, and restrictions set forth in this deed shall be covenants running with the land for the benefit of Grantor and shall be binding on Grantee, its successors and assigns.

When the context requires, singular nouns and pronouns include the plural.

"Grantor"

FRIENDSWOOD DEVELOPMENT COMPANY

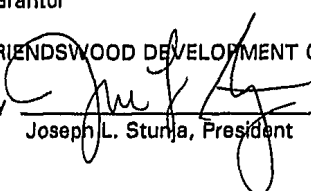
By  /or  
Joseph L. Sturja, President

"Grantee"

KINGS HARBOUR JV63, a Texas general partnership, by and through its two general partners.

By: First Kingwood Investments, L.P., a Texas limited partnership 

By: Clear Lake Development Corp., a Texas corporation, its sole general partner 

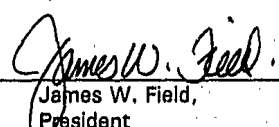
By:   
James W. Field,  
President

By: Luna Bay, Ltd., a Texas limited partnership 

By: Arcanum VII LB-GP, Inc., a Texas corporation, its sole general partner 

By:   
John Coffman, President

510-00-2292

STATE OF TEXAS       §  
                                  §  
COUNTY OF HARRIS   §

BEFORE ME, the undersigned authority, on this day personally appeared JOSEPH L. STUNJA, PRESIDENT OF FRIENDSWOOD DEVELOPMENT COMPANY, a Florida corporation, known to me to be that person whose name is subscribed to in the foregoing instrument, and acknowledged to me that he executed the same on behalf of said corporation and for purposes and consideration therein expressed.

GIVEN UNDER MY HAND AND SEAL of office this 21<sup>st</sup> day of November, 1996.

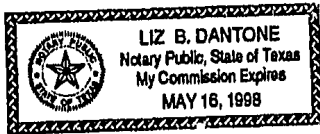

Liz B. Dantone  
Notary Public, State of Texas

STATE OF TEXAS       §  
                                  §  
COUNTY OF HARRIS   §

BEFORE ME, the undersigned authority, on this day personally appeared JAMES W. FIELD, PRESIDENT OF CLEAR LAKE DEVELOPMENT CORP., AS THE SOLE GENERAL PARTNER OF FIRST KINGWOOD INVESTMENTS, L.P., A TEXAS LIMITED PARTNERSHIP, GENERAL PARTNER OF KINGS HARBOUR JV63, known to me to be the person whose name is subscribed to in the foregoing instrument, and acknowledged to me that he executed the same for purposes and consideration therein expressed.

GIVEN UNDER MY HAND AND SEAL of office this 22<sup>nd</sup> day of November, 1996.

Sue R. Hays  
Notary Public, State of Texas

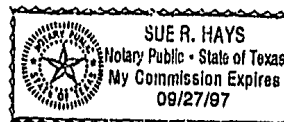

510-00-2293

STATE OF TEXAS       §  
                                  §  
COUNTY OF HARRIS   §

BEFORE ME, the undersigned authority, on this day personally appeared JOHN COFFMAN, PRESIDENT OF ARCANUM VII LB-GP, INC., AS THE SOLE GENERAL PARTNER OF FIRST KINGWOOD INVESTMENTS, L.P., A TEXAS LIMITED PARTNERSHIP, GENERAL PARTNER OF KINGS HARBOUR JV63, known to me to be the person whose name is subscribed to in the foregoing instrument, and acknowledged to me that he executed the same for purposes and consideration therein expressed.

GIVEN UNDER MY HAND AND SEAL of office this 22nd day of November, 1996.

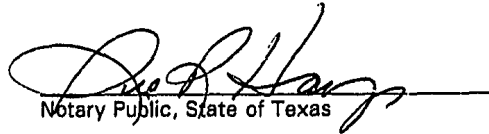
  
Notary Public, State of Texas

L283

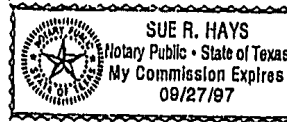

EXHIBIT "A"

510-00-2294

Metes and Bounds Description  
63.568 Acres  
Amasa Turner Survey, Abstract 757  
Harris County, Texas

Being a tract or parcel containing 63.568 acres (2,769,031 square feet) of land situated in the Amasa Turner Survey Abstract No. 757, Harris County, Texas, being out of and a part of that certain called 2,823.15 acre tract (Tract 4) described in a deed from Foster Lumber Company to King Ranch, Inc. recorded in Volume 7036, Page 323 of the Harris County Deed Records (H.C.D.R.). Said 63.568 acre tract being more particularly described as follows with all bearings referenced to the Texas Coordinate System, South Central Zone:

BEGINNING at an "X" cut in a concrete sidewalk for the corner common to the southwest corner of Restricted Reserve "A", Kings Crossing Section Nineteen according to the map or plat recorded under Film Code Number 345127, of the Harris County Map Records (H.C.M.R.) and the northwest corner of the herein described tract, also being in the existing easterly right-of-way line of Lake Houston Parkway (width varies) of record under Film Code 350032 of said H.C.M.R.;

THENCE, North 20°31'36" East, 35.22 feet along the southerly line of said Restricted Reserve "A", to a 3/4-inch iron rod with a plastic cap stamped "SURVCON INC." found for an angle point;

THENCE, North 22°45'14" East, continuing along said southerly line, 35.68 feet to a 5/8-inch with a plastic cap stamped "SURVCON INC." found for the most northerly corner of the herein described tract;

THENCE, along the easterly line of the herein described tract the following courses;

South 23°11'55" East, 373.72 feet to a 5/8-inch iron rod with a plastic cap stamped "SURVCON INC." found for an angle point;

South 41°20'52" East, 333.02 feet to a 5/8-inch iron rod with a plastic cap stamped "SURVCON INC." found for an angle point;

510-00-2295

South 59°58'54" East, 259.86 feet to a 5/8-inch iron rod with a plastic cap stamped "SURVCON INC." found for an angle point;

South 76°25'01" East, 766.44 feet to a 5/8-inch iron rod with a plastic cap stamped "SURVCON INC." found for an angle point;

South 52°18'21" East, 278.03 feet to a 5/8-inch iron rod with a plastic cap stamped "SURVCON INC." found for an angle point;

South 20°57'21" East, 503.29 feet to a 5/8-inch iron rod with a plastic cap stamped "SURVCON INC." found for an angle point;

South, 680.00 feet to a 5/8-inch iron rod with a plastic cap stamped "SURVCON INC." found for an angle point;

South 61°29'42" East, 453.33 feet to a 5/8-inch iron rod with a plastic cap stamped "SURVCON INC." found for the most easterly corner of the herein described tract, and being in the northerly line of that certain called 1,779.75 acre tract (Tract #7) described in deed from Foster Lumber Company to the City of Houston recorded in Volume 2211, Page 39 of said H.C.D.R.;

THENCE, along said northerly line the following courses;

South 47°29'51" West, 1,270.22 feet to an angle point;

North 52°30'18" West, 554.86 feet to an angle point;

North 85°40'52" West, 239.90 feet to a 5/8-inch iron rod with a plastic cap stamped "SURVCON INC." found for an angle point;

South 18°58'58" West, 518.40 feet to a 3/4-inch iron rod with a plastic cap stamped "SURVCON INC." found for the most southerly corner of the herein described tract, being in the aforementioned existing westerly right-of-way line of Lake Houston Parkway;

THENCE, along said existing westerly right-of-way line of Lake Houston Parkway the following courses;

North 73°03'45" West, 10.93 feet to a 3/4-inch iron rod with a plastic cap stamped "SURVCON INC." found for corner;

510-00-2296

North 11°13'38" East, 301.50 feet to a 3/4-inch iron rod with a plastic cap stamped "SURVCON INC." found for an angle point;

North 16°56'16" East, 434.04 feet to an "X" in concrete sidewalk found for the beginning of a tangent curve to the left;

Northerly, 2,062.66 feet along the arc of said curve (Central Angle = 47°16'22"; Radius = 2,500.00 feet; Chord Bearing and Distance = North 06°41'55" West, 2,004.65 feet) to a 3/4-inch iron rod with a plastic cap stamped "SURVCON INC." found for the point of tangency;

North 30°20'06" West, 100.00 feet to a 3/4-inch iron rod with a plastic cap stamped "SURVCON INC." found for the beginning of a tangent curve to the right;

Northwesterly, 311.40 feet along the arc of said curve (Central Angle = 07°08'12"; Radius = 2,500 feet; Chord Bearing and Distance = North 26°46'00" West, 311.19 feet) to a 3/4-inch iron rod with a plastic cap stamped "SURVCON INC." found for the point of tangency;

North 23°11'55" West, 323.45 feet to the POINT OF BEGINNING, containing a computed area of 63.568 acres (2,769,031 square feet) of land.

This description to accompany a plat.

Compiled by:  
SURVCON INC.  
Houston, Texas  
Job No. 5806-45 TR 3  
Job No. 5806-74  
Job No. 5860-14  
November, 1995  
Revised: 12-20-95  
Revised: 3-13-96  
Revised: 11-15-96  
D-11

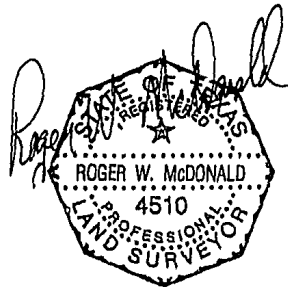

11/15/96



510-00-2297

EXHIBIT "B"

To Special Warranty Deed between  
FRIENDSWOOD DEVELOPMENT COMPANY  
and  
KINGS HARBOUR JV63

PROTECTIVE COVENANTS

The Property shall be developed, improved, sold, used and enjoyed in accordance with, and subject to the following plan of development, including the covenants, conditions and restrictions hereinafter set forth (the "Protective Covenants"), all of which are hereby adopted for, and placed upon said Property and shall run with the Property and be binding upon all parties, now and in any time hereafter, having or claiming any right, title or interest in the Property or any part thereof, their heirs, executors, administrators, successors and assigns, regardless of the source of, or the manner in which such right, title or interest is or may be acquired; provided, however, these Protective Covenants shall cease to exist and be of no further force or effect any time that title to the Property is revested in Grantor, its successors or assigns.

1. Use. The Property may be used in whole or in part for the construction, maintenance, and operation of a mixed-use commercial and/or residential development and for no other purpose or purposes. Additionally, the following uses are prohibited: the sale and storage of petroleum products, automotive repair services, and the operation of a grocery store or market, but for no other purpose or purposes. Provided, however, that from and after twenty (20) years from the date of the conveyance of the Property from Grantor to Grantee, the Property may be used in whole or in part for any commercial or office use but only so long as all buildings, structures, additions, signs and other improvements erected or maintained thereon (i) are in harmony of design with, the buildings, structures, additions, signs, and other improvements if any, located on adjoining Property, and (ii) are in conformance with these Protective Covenants, but only so long as all buildings, structures, additions, signs and other improvements erected or maintained thereon are in conformance with these Protective Covenants.

2. Declaration of Covenants, Conditions and Restrictions Required. No building, wall, fence, permanent sign or structure shall be commenced on the Property until a declaration of conditions, covenants and restrictions affecting all of the Property is executed by Grantee and filed in the Harris County Real Property Records. Said declaration of covenants, conditions and restrictions shall be subject to approval in writing by Grantor, which approval shall not be unreasonably withheld. All changes, variances and/or amendments to the above mentioned declaration of covenants, conditions and restrictions are subject to approval in writing by Grantor, which approval shall not be unreasonably withheld. If this covenant is breached by Grantee or its successors and assigns, then Grantor may seek injunctive relief to stop construction and recover reasonable counsel fees from Grantee or its successors or assigns. Said declaration of covenants, conditions and restrictions shall require development guidelines which shall be equal to or more stringent than Grantor's Development Guidelines for Kingwood (the "Development Guidelines") adopted by Grantor for said Property and other commercial properties in the area and attached hereto as Exhibit "A" to the Protective Covenants.

510-00-2298

3. Grantor Approval Required. No building, structure, addition, sign, or other improvement may be constructed, remodeled, replaced or altered in any manner on the Property until the construction plans and specifications (including, but not limited to, site layout, building and sign location, building material, dimensions, elevations, utility layout, the design and color scheme of all permanent and temporary signs, site and off-street parking of vehicles, landscaping and exterior lighting) have first been submitted to and approved in writing by Grantor. Such approval shall be to (a) insure compliance with these Protective Covenants and with Grantor's Development Guidelines for Kingwood (the "Development Guidelines") adopted and promulgated and amended from time to time by Grantor for said Property and other commercial properties in the area; and (b) confirm the Kingwood quality of materials, color, harmony of external design with existing and proposed structures, and the location and finish grade elevations of the improvements with the surrounding topography. Signs offering the property for lease or sale are permitted prior to the filing of a declaration of covenants, conditions and restrictions provided however that the signs are subject to Grantor approval and in conformance with the Development Guidelines.

Grantee shall have the right to three esplanade cuts on Lake Houston Parkway located generally in conformance with the Kings Crossing Land Use Plan as shown on Exhibit "B" to the Protective Covenants. The location of such esplanade cuts shall be subject to review and approval of the Architectural Review Committee (the "ARC") and applicable governmental authorities prior to commencement of construction.

Grantee shall have the right to six curb cuts along the east side of Lake Houston Parkway. The location of the curb cuts shall be subject to review and approval of the ARC and applicable governmental authorities prior to commencement of construction.

During Grantee's construction activity and prior to pouring of concrete for building slab(s) and access driveways, Grantee shall deliver to Grantor at 810 Kingwood Drive, Kingwood, Texas 77339, Attn: Project Engineer, notification in writing forty-eight (48) hours prior to the pouring of such concrete in order for Grantor or its representative to inspect the location of the building slab(s) and driveway access areas for compliance with these Protective Covenants and the Development Guidelines. Grantee shall not proceed with construction activity, including the pouring of concrete, unless and until Grantor approves the location of such building slab(s) and driveway access areas in writing.

Reference is here made to the Development Guidelines for all construction, remodeling, replacement or alteration of any building, structure, sign, addition, or other improvement, which Development Guidelines may be amended from time to time by Grantor. The construction, remodeling, replacement or alteration of any building, structure, addition, sign or other improvement shall comply with the Development Guidelines as they now exist or as they may hereafter be amended. However, such amendments shall not retroactively apply to existing improvements.

Approval of plans and specifications by Grantor is only for the purposes above described and specifically, but without limitation, shall not be construed as any representation by Grantor as to, or responsibility for, design or quality of improvements or the ultimate construction thereof. Any and all plans and specifications submitted to

510-00-2299

Grantor which have not been disapproved within thirty (30) days after the date of submission shall for all purposes be deemed to have been approved. If Grantor should disapprove plans and specifications submitted to it, other than plans and specifications for a sign, and Grantor and Grantee are not able to resolve such differences within thirty (30) days after disapproval, then, following Grantee's written request therefor, Grantor may, at Grantor's option, repurchase the Property from Grantee, for the original purchase price in cash, and Grantee shall thereupon reconvey the Property to Grantor by special warranty deed free and clear of all liens and encumbrances other than those to which the conveyance of the Property from Grantor to Grantee was subject. The decision of Grantor not to exercise said repurchase option shall in no way impair or alter the obligations of Grantee as set forth herein.

4. Offensive and Prohibited Uses. No use of the Property shall be permitted which is illegal, or offensive in the reasonable opinion of Grantor by reason of odor, fumes, dust, smoke, noise, or pollution, or hazardous by reason of excessive danger of fire or explosion. In addition, no activity or use shall be permitted on or with respect to any part of the Property which is, in Grantor's reasonable opinion, obnoxious to or out of harmony with the development of the immediate community in which the Property is located, including, but not limited to, the operation of (a) any trailer court, junk yard, scrap metal yard or waste material business (including any dumping, disposal, incineration or reduction of garbage or refuse, but this restriction shall not preclude the use of compacting devices on the Property which temporarily hold refuse for disposal off-site when such devices are used in conjunction with a Property use or business which is not a junk yard, scrap metal yard, or waste material business); (b) a used clothing business or a business that specializes in bankruptcy or liquidation sales or the selling of fire damaged items, (c) an auction house or flea market; (d) an office for the practice of veterinary medicine, only if the operation of such veterinary office includes the use of kennels, runs, or any other related facilities located outside the building or other structures constructed in accordance with the Development Guidelines and approved by the ARC (veterinary practices dealing with large animals such as cattle and horses are specifically prohibited); (e) a kennel or business involving the boarding of animals, except in connection with an office for the practice of veterinary medicine, as described in (d) above; (f) a garage, gasoline service station or other establishment for the sale of motor fuel or other petroleum or energy products; or (g) an "adult" bookstore, theater, studio, parlor or other facility, any of which show on-premise X-type rated or unrated pornographic motion pictures or video films or provide forms of entertainment appealing to the prurient interests of the general public or would otherwise diminish the reputation or alter the family-oriented character of the community in which the Property is located. No building, structure, addition, sign, or other improvement shall be erected, maintained, or permitted upon any portion of the Property that would be used for the aforesaid offensive and/or prohibited uses.

5. Open Spaces. A minimum of twenty (20) percent of the Property (a) may not be improved by the construction of a building or buildings thereon or be paved or blacktopped for vehicular access or parking and (b) must be landscaped and shall have an irrigation system installed throughout, all in accordance with plans approved by Grantor. If classified wetlands make up, in part or in whole, the open space required by this covenant, planned landscaping and irrigation will not be required to the extent that it may cause the wetland areas to fail to qualify as such under permits or plans approved by

510-00-2300

the Corps of Engineer or a qualified environmental consultant approved by Grantor. Any designated landscape easement within the Property's boundaries may be included in open space calculations.

6. Setbacks. Minimum building and parking setbacks shall be as follows (measured from the property lines or future subdivision property lines):

	<u>Building</u>	<u>Parking</u>
From Lake Houston Parkway	50'	50'
From major collector streets	25'	25'
From all other property lines	10'	10'

No parking areas and/or paved area for vehicular circulation (except driveways which directly access a public right-of-way) shall be located within any setback area. Existing trees and landscaping located within building and parking setback areas or adjacent street right-of-way shall be fenced during construction activity in order to preserve such existing landscaping. The location of such fencing and access areas shall be subject to written approval by the ARC. Access to the property across the setback areas for construction purposes shall be restricted to the areas designated for permanent driveway access, which are subject to review and approval by the ARC and applicable governmental authority prior to commencement of construction. Notwithstanding anything contrary herein, there shall be no minimum setback requirement from any adjoining property owner by Purchaser.

7. Building Height. All buildings and improvements erected on the Property shall be limited to a maximum of three stories in height except the area identified on Exhibit "C" to the Protective Covenants which shall be limited to a maximum of ten stories in height.

8. Parking Requirements. Automobile parking spaces, sufficient in number for all employees and customers/visitors, shall be provided on-site, and all parking areas shall be internally drained, curbed and paved. Minimum parking requirements/spaces shall be in accordance with the Development Guidelines unless otherwise approved in writing by Grantor.

9. Loading/Unloading. Loading and unloading of delivery vehicles shall occur on-site only; on-street delivery vehicle loading and unloading shall not be permitted. Loading/unloading facilities shall be separated from employee, customer and visitor circulation and parking areas and shall be screened from public view in a manner approved in writing by Grantor prior to construction.

10. Outside Storage or Operations. No outside storage or operations of any kind shall be permitted unless such activity is visually screened from public view in a manner which is architecturally compatible and approved in writing by Grantor prior to construction. No boats, trailers, campers, horse trailers, buses, inoperative vehicles of any kind, camping rigs off truck, boat rigging, or other vehicles or associated equipment of recreational or commercial nature shall be parked or stored permanently or semi-permanently on the Property or any part thereof unless properly screened from public view in a manner approved in writing prior to construction by Grantor. All retail sales

510-00-2301

equipment, fixtures and merchandise shall be displayed only in the interior of a building, unless done in a manner approved in writing by Grantor prior to construction. Water towers, cooling towers, communication towers, storage tanks and other structures or equipment shall be architecturally compatible with the aesthetics of the project or effectively shielded from public view. All utility/service system components and trash pick-up stations shall be integrated with the building or screened by a fence or wall of compatible materials not less than eight (8) feet high and shall not be visible above such screening. All fences or walls shall be approved in writing by Grantor prior to construction.

11. Mechanical Equipment. All roof-top mechanical equipment shall be screened from the view of adjacent streets and buildings with material compatible with the building architecture or by the use of parapet wall. Such screening and/or parapet wall shall be equal to or greater than the height of the roof top mechanical equipment. All power transformers shall be ground mounted and screened from public view by fencing or landscaping, all of which must be approved in writing by Grantor.

12. Grading and Drainage. Surface drainage shall be collected on-site and connected to underground storm drain structures. Care shall be taken not to cause damage to adjacent properties during construction or after completion of the project. Grading of the site shall be done without damaging existing trees in proposed open space areas (as defined in Paragraph 4).

13. Underground Utilities. Any pipe, conduit, cable, or line for water, gas, electricity, sewage, drainage, or steam shall not be installed or maintained (a) outside of any building or (b) above the surface of the ground within the Property, unless otherwise approved in writing by Grantor.

14. Exterior Illumination. Exterior illumination, if such is to be provided, shall be designed to light only buildings, parking areas and walkways and shall not produce glare or splashover on adjacent streets or properties. All ground level floodlighting fixtures shall be depressed or screened from public view in a manner approved in writing by Grantor. Parking area lighting units, arcade lighting or any other lighting shall be in a style and color approved by Grantor.

15. Signs. All signs and their locations must be approved by Grantor in writing prior to installation. No sign of a flashing or moving character shall be installed, and no sign shall project above the roof line of a building unless approved in writing by Grantor. Any sign installed without Grantor's approval may be removed by Grantor, without liability for trespass or other legal wrong in Grantor. For the purposes of this provision signing shall include, without limitation, flags and flagpoles, awnings, mobile trailer signs, canopies, banners, and advertising placed on walls, automobiles, windows, or other objects located on the Property.

16. Prohibited Structures. No metal fabricated buildings, trailers, tents, shacks, barns, or temporary building or structures, other than construction offices and structures for related purposes during the construction period, may be installed or maintained on the Property without the prior written approval of Grantor. All temporary structures used

510-00-2302

for construction purposes must receive approval by Grantor with regard to location and appearance, and must be removed promptly upon completion of construction.

17. Maintenance. The Property shall be maintained in a neat and clean condition. Grantee shall (a) keep all weeds and grass thereon cut in a sanitary, healthful, and attractive manner, (b) not permit the accumulation of garbage, trash, or rubbish of any kind thereon, and (c) not burn anything thereon except by use of an incinerator which is approved by Grantor.

18. Attorneys' Fees. Grantee and/or any person or business entity occupying the Property shall be liable for all expenses, including but not limited to attorneys' and professional fees, incurred by Grantor in acting against Grantee and/or any person or business entity occupying the Property to cause compliance with or to cure violations of these Protective Covenants.

19. Variances. Grantor has the exclusive right and hereby retains the exclusive right to approve variances or otherwise change, rescind, or modify these Protective Covenants where in its judgment, any such variance will not adversely affect the development of Kingwood.

20. Assignment. Grantor has and hereby retains the right to assign, in whole or in part, its rights hereunder, including, but not limited to, the right to approve or disapprove plans and specifications and the right to grant deviations. In the event Grantor elects to assign such rights, such assignment shall be evidenced by an instrument in writing, executed and acknowledged and filed in the appropriate Real Property Records of Harris County, Texas.

21. Severability. Invalidation of any one of the covenants, conditions or restrictions of these Protective Covenants shall not affect any other provision, which shall remain in full force and effect.

22. Binding Effect. These Protective Covenants shall be binding upon and inure to the benefit of Grantor, Grantee, and their respective successors and assigns.

23. Governing Law. These Protective Covenants shall be governed by and in accordance with the laws of the State of Texas.

24. Terminology. The captions beside the numbered Paragraphs herein are for convenience only and shall not limit, enlarge, modify, or otherwise affect these Protective Covenants in any manner whatsoever. Whenever required by the sense and circumstances of the context of these Protective Covenants or of any deed which these Protective Covenants have been made a part thereof, any gender shall include any other gender, the singular shall include the plural, and the plural shall include the singular.

25. Performance. Any obligations hereunder are performable in Harris County, Texas, and any and all payments that are made hereunder are to be made in Harris County, Texas.

L256

510-00-2303

EXHIBIT "A" TO PROTECTIVE COVENANTS

FDC



COMMERCIAL  
DEVELOPMENT GUIDELINES

For Master-planned Communities  
of  
Friendswood Development Company  
1994

510-00-2304

## Table of Contents

<b>I.</b>	<b>Introduction and Philosophy</b>	
A.	General Commercial Information	I-1
B.	Architectural Review	I-2
C.	Approval Procedures	I-2
D.	Variances	I-5
<b>II.</b>	<b>General Development Guidelines</b>	
A.	Site Planning	
1.	Open-Space Requirement	II-1
2.	Setback Requirements	II-2
3.	Landscape Requirements	II-2
4.	Building Orientation	II-4
5.	Vehicular Access	II-4
6.	Service Access and Service Areas	II-5
7.	Outside Storage Operations	II-5
8.	Pedestrian Access	II-5
9.	Minimum Parking Requirements	II-6
10.	Parking Lot Design Standards	II-6
11.	Parking Garages	II-7
12.	Drainage	II-7
13.	Easements	II-8
B.	Site Elements	
1.	Utility Areas and Communication Equipment	II-8
2.	Trash Receptacles and Enclosures	II-9
3.	Screen Walls and Fencing	II-9
4.	Mailboxes	II-10
5.	Flagpoles	II-10
6.	Lighting	II-10
7.	Site Furnishings	II-11
8.	Helicopter Pads	II-12
C.	Structures	
1.	Building Design and Character	II-12
2.	Energy Conservation	II-13
3.	Exterior Materials and Colors	II-14
4.	Roof Design and Materials	II-14
5.	Roof-top Equipment	II-14
6.	Pedestrian Arcades	II-15
7.	Awnings	II-15
8.	Burglar Bars	II-16
D.	Signage	
1.	Special Purpose Signs	II-17
2.	Ground-Mounted Monument - Highway Location	II-18
3.	Ground-Mounted Monument - Non-Highway Location	II-21
4.	Building-Mounted Signs	II-26
5.	Building and Unit Address	II-29
6.	Under Canopy - Retail	II-29
7.	Window Signs	II-30
8.	Directional and Delivery Signs	II-31
9.	Reserved and Visitor Parking Space Signs	II-31
10.	Regulatory Signs	II-32



510-00-2305

D. Signage con't.	
11. Exterior Directories	II-32
12. Construction Signage	II-33
13. Leasing / For Sale Signage	II-35
14. Promotions	II-37
15. Outdoor Displays	II-38

III. Appendix A

A. Landscape Installation	
1. Landscaped Edges	III-1
2. Accent Treatments	III-1
B. Recommended Landscape Planting List	III-1
1. Street Trees/Parking Lot Trees/Background Trees	III-1
2. Accent Trees/Group Planting/Plazas	III-1
3. Shrubs - Hedges, Screen	III-2
4. Shrubs - Accents, Massing	III-2
5. Ground Covers - Plazas/Buildings	III-3
6. Ground Covers - Parking Lots	III-3
7. Vines - Buildings, Walls, Fences	III-3
8. Perennials - Plazas, Buildings	III-3
9. Grasses	III-3

IV. Appendix B

A. Construction Controls	
1. Tree Preservation	IV-1
2. Site Clearing	IV-2
B. Guidelines for Construction Activity	IV-2
1. Equipment Access and Construction Parking	IV-2
2. Temporary Structures and Fences	IV-2
3. Construction Debris	IV-2
4. Materials Storage	IV-3
5. Erosion and Sediment Control	IV-3
6. Construction Hours	IV-3
C. Street Paving	IV-3

V. Appendix C

A. Definitions	
----------------	--

510-00-2306

## I. Introduction and Philosophy

Friendswood Development Company (FDC) communities are constantly evolving due to changing consumer expectations and public regulations. Typically, this evolution reflects changing market and regulatory conditions. Thus, it is important that each FDC community have an overall set of policies and standards to provide a framework for dealing with these changes. In an effort to protect and enhance property values by encouraging and guiding compatibility of site, building and signage design in new and existing development, FDC has created these Commercial Development Guidelines.

These Guidelines are designed to serve as a key mechanism by which FDC communities *guide* their commercial development. They give landowners considerable flexibility in developing their property as long as their projects conform to certain criteria designed to protect the integrity and value of the community. The basic purpose of these Guidelines is to encourage quality design and character while mitigating undesirable impacts before they develop. FDC strongly believes that these ideals can be accomplished through a creative effort between Friendswood Development Company and other private enterprises.

*The Commercial Development Guidelines are not intended to be an absolute design regulation nor presume to predict all possible site specific conditions.*

### A. General Commercial Information

FDC's commercial development classifications were established as a control mechanism. Commercial classification uses are defined as follows:

#### 1. Retail and Commercial

Free-standing retail, retail shopping centers, service stations, cinemas, hotels, restaurants, banks, entertainment facilities, research and development facilities, service/distribution centers, showrooms, auto dealerships, and related retail uses.

#### 2. Office

Professional office buildings freestanding or campus style.

#### 3. Institutional

School and church sites, day care facilities, library, hospital, government or community buildings, etc.

#### 4. Multi-Family Residential Attached Units

Multi-family residential development including apartments, townhouses and patio homes of medium (5 to 18 units per net acre) and high density (18 or more units per net acre).

#### B. Architectural Review (for uses other than single-family residential construction)

To insure the integrity of the development concepts defined in these Guidelines and in accordance with applicable declarations, the following activities must be reviewed and approved by the appropriate Architectural Review Committee (ARC) prior to commencement:

**Clearing**  
**Demolition**  
**New construction**  
**Signage (temporary and permanent)**

This document provides general development guidelines to property owners in Friendswood Development Company communities. However, the ARC will apply flexibility and latitude in its approval and disapproval of plans and specifications. This flexibility can allow the ARC to accommodate individual project master-plan objectives. It is the responsibility of the builder/developer to provide substantiating information to the ARC on all special conditions or circumstances regarding a deviation from these guidelines.

It is the responsibility of the builder/developer to become thoroughly familiar with these Guidelines and to raise questions of interpretation at the earliest possible time.

#### C. Approval Procedures

The Architectural Review Committee (ARC) approval consists of a two-step process: Preliminary Plan Approval, and Final Construction Plan Approval. A pre-planning discussion with the ARC is recommended to highlight any specific sensitivities that may exist. The approval process may include referral to a qualified outside consultant.

Following review by the ARC at Step 1 and Step 2, a summary letter stating the results of the review will be mailed to the builder/developer within thirty (30) days of the submittal. The ARC will endeavor to expedite the review and response process.

510-00-2308

**Step 1: Preliminary Plans.** The builder/developer is required to submit the following preliminary information when available:

**Floor plans**

**Exterior building elevations**

**Site plan**

- Site size (acreage)
- Existing improvements on site (utilities, fencing)
- Percentage of site devoted to open space
- Existing vegetation locations within proposed setbacks or reserves that may be impacted by land use, driveway or services access parking lots, or median cuts.
- Building(s) location and size (square footage)
- Building and parking setbacks/dimensions
- Parking lot(s) configuration, ratio and capacity
- Service area(s), trash receptacle, and mechanical equipment locations (with screening method)
- Proposed fencing and/or screening walls
- Satellite/antenna dish location (with screening method)
- Proposed signage location(s)
- A note outlining the builder/developer's understanding of maintenance and irrigation boundaries for the site where the site adjoins an existing maintained landscape setback.

Plans should be drawn in a format typically produced by a registered professional architect. The builder/developer may wish to submit a rendering or sketch of exterior building appearance as a supplement to this submittal.

ARC approval of preliminary plans does not constitute ARC acceptance of the final construction drawings or approval to begin construction. All information required in Step 2: Final Construction Plan Review must be submitted and approved in writing prior to any construction. The ARC may convene and act on special occasions in an effort to accommodate unusual situations where justified. These procedures are part of the overall effort to insure that an acceptable quality level is attained without the necessity of imposing undue, cumbersome regulation.

**Step 2: Final Construction Plans.** Upon completion and approval of Preliminary Plans (Step 1), the builder/developer may submit Final Construction Plans (Step 2). The submittal should include the following:

**Site Plan**

- Utility layouts on site (approval(s) by appropriate agencies required)
- Landscape plans and tree preservation plan

Exterior lighting plans (including photo meters details)  
Signage plans and elevation(s) (temporary and permanent locations)  
Architectural elevations (all sides)  
Exterior material and color samples

Additionally, the Owner's construction contact and field superintendent's name and telephone number must be provided to the ARC.

It is recommended that the builder/developer engage a registered professional architect, landscape architect, and engineer for the preparation of the project plans, specifications, and construction administration services.

All components of building and site design must adhere to the local codes having jurisdiction. Projects in the city of Houston must adhere to the City of Houston Building Code, Development Ordinance, Landscape Ordinance, Parking Ordinance and/or any other applicable codes, statutes, regulations or ordinances. Where no local code is in effect, the Standard Building Code shall be used for the basis of construction. The builder/developer is responsible for obtaining all local county Flood Control and Utility District approvals. The builder/developer will also be responsible for determining the nature of restrictions associated with pipeline or utility easements which may be located on the site. The ARC will not be responsible for the interpretation of any building codes or ordinances. ARC approval of submitted plans does not constitute compliance with any governmental codes, ordinances or regulations, nor does ARC approval release the builder/developer from the responsibility of compliance with all codes, ordinances, or regulations in effect.

The builder/developer is responsible for abiding by all Non-Point Discharge Elimination System (NPDES) regulations as promulgated by EPA in September 1992. Additional Guidance has been issued by the City of Houston and Harris County. To this effort, the builder/developer must prepare a Pollution Prevention Plan (PPP) for the construction site, including an erosion and sedimentation control plan for the site which must be included in the construction drawings. The builder/developer is also responsible for submitting a Notice of Intent (NOI) to EPA for compliance with EPA's General Permit. Friendswood Development Company retains the right, but not the obligation, to request a copy of the builder/developer PPP and to make on-site inspection and reasonable changes to ensure adequate erosion protection.

No construction may commence until plans have been approved by the ARC. The ARC reserves the right to enforce compliance with the approved plans by legal means as necessary.

510-00-2310

I-5

#### **D. Variances**

The ARC will consider the potential negative impact and precedent that may be set within the community regarding a variance request. Variances may be granted in situations where the builder/developer can fully satisfy the ARC that adherence to the guidelines:

1. Presents a significant hardship to the project.
2. An alternate approach which exceeds the intent of these Guidelines is preferable; and/or
3. the Guidelines do not adequately address a specific condition;
4. a precedent within close proximity to the site has previously been set;
5. the variance does not set a negative precedent within the community.

The builder/developer should not plan or design any portion of a project on the assumption of receiving a variance to these guidelines. It is suggested that the builder/developer contact the ARC immediately should the adherence to the Guidelines propose a potential problem or as questions arise regarding the interpretation of these guidelines. Further, the ARC shall not be responsible for any re-design caused the builder/developer as a result of misinterpretations of the Guidelines.

## II. General Development Guidelines

### A. Site Planning

Planning for site entrances, landscape design, pedestrian access, vehicular access and parking, building location and character, security, and site utilities must be executed to preserve existing site improvements and landscaping where possible. All site planning must meet the criteria listed below.

#### 1. Open Space Requirement

Open space is defined as land not covered by building structures or used for automobile circulation and/or parking. However, open space may include landscape reserves, swimming pools, tennis courts, and pedestrian sidewalks within a landscape area. All open space must be landscaped and irrigated unless it remains as undisturbed forest, wetland, or other natural area. Open space does not include street rights-of-way.

Open-space requirements are as follows:

<u>Use</u>	<u>Open Space Required</u>
Retail, Commercial and Office Buildings	
Sites under 5 acres	20%
Sites over 5 acres	10%
Institutional	
Schools (excluding ball fields), churches, etc.	20%
Multi-Family Residential	
8 to 18 units / acre with 250 s.f. of courtyard/unit	30%
8 to 18 units / acre without a courtyard/unit	40%
Over 18 units / acre with 250 s.f. of courtyard/unit	20%
Over 18 units / acre without a courtyard/unit	30%
Business Parks, Service/Distribution, Office Showrooms	
Kingwood	30%
Most Communities	20%

Note: For multi-family residential projects, it is recommended that each unit be provided with two hundred (200) square feet of private open space with a view of a landscaped greenbelt, courtyard or general open space.

510-00-2312

2. Setback Requirements

Setback areas, including easements, must be landscaped and irrigated unless they remain as forest, wetland, or other natural area. Setbacks are measured from the property line.

Setbacks are required, as indicated below, along all public streets and interior property lines unless specifically altered by Friendswood Development Company in the deed or by City of Houston requirements. None of these setbacks may be paved except for driveway and sidewalk crossings approved by the ARC.

<u>Area</u>	<u>Building/ Parking Setbacks</u>	<u>Building Setback</u>	<u>Parking Setback</u>
Major Highway (interstate, freeway)	75 feet		
Minor Highway	50 feet		
Major Thoroughfare/Artery			
- Most Communities	25 feet		
- Kingwood	50 feet*		
Collector Street between Thoroughfares	25 feet*		
Local/Neighborhood Streets		25 feet	10 feet
Side or Rear Lot Line**			
- Adjacent to non-residential	10 feet		
- Adjacent to residential		25 feet	10 feet
- Adjacent to greenbelt	10 feet		

\* Unless modified by the ARC.

\*\* When setback accommodates a utility easement, the setback must be increased by five feet (5').

3. Landscape Requirements

Master-planned communities include quality landscaping in setbacks, reserves, and open spaces. At a minimum, all sites must comply with the City of Houston or other applicable local Landscape Ordinance. When such an ordinance is unavailable, the following minimums must be met: All projects must be landscaped and irrigated to complement the quality and design of the landscaping on the adjacent public streets or greenbelts and blend with the residential areas. All landscape and irrigation plans must be submitted to the ARC for review and approval.



a. Setbacks

All sides of a project are visually important. The front and side setbacks should receive equal attention. All setbacks in non-forested areas must be landscaped with a combination of low growing shrubs and trees. Berms may be used in lieu of low growing vegetation. Tree clustering is encouraged. All berms should be kept to a slope of 3:1 or less with a maximum height of four feet (4'). Landscape treatment which exceeds the Landscape Ordinance is encouraged in front setbacks along public streets. Particular attention should be given to screening parking lots from the public rights-of-way. The ARC reserves the right to determine the appropriate level of landscape required which may exceed those requirements as outlined in the Landscape Ordinance.

b. Parking Lots

Landscaping and the planting of shade trees for sun screening is required in parking lots and along pedestrian walkways. For sites larger than five (5) acres, parking lots are required to have landscaped areas or "islands" totaling at least 5% of the parking lot area.

For parking lots with more than sixteen (16) parking spaces, one (1) tree is required for every ten (10) parking spaces. Trees should be shade providing canopy varieties at least two and one-half (2-1/2) inches in caliper and at least twelve feet (12') in height.

c. Plant Species

Plant species for all landscaped islands should be carefully selected for tolerance to exhaust fumes and pavement heat. Trees that drop sap are to be avoided as are trees that drop large amounts of blossoms, seeds, and pods that may clog drains. Additionally, the use of trees that are susceptible to insects and disease, as well as trees with expansive root systems that could disrupt paving and underground lines, should be avoided. Please see Appendix A: Recommended Landscape Planting List.

d. During Construction

If landscaping exists in the proposed setbacks, it must be retained and protected during construction. Existing trees installed within the last three (3) years in landscape setbacks and located at proposed driveway

locations must be relocated within the setback or replaced with equal specimens. Elsewhere on the site, existing trees should be saved wherever possible and incorporated into the required open space.

#### 4. Building Orientation

When orienting and locating the building(s) on a site, visibility and privacy issues from adjacent roads, location of existing trees, parking lot circulation, any pedestrian connections to adjacent buildings or parcels, energy conservation, and impacts to adjacent buildings, existing or future, should be considered .

Buildings are a positive influence in creating a community and public space. Where appropriate to the site, buildings should be oriented to the street. The parking lot should be internal to the site and screened from the street -- an arrangement which accents the building, promotes pedestrian traffic and enhances the street scene.

For multi-family projects, the entry drive into the site should feature landscaped medians. Parking lots and covered parking structures should occur on the interior of the site. Individual units should be oriented to the street or amenity whenever possible. When living units face directly onto a street, setbacks may be increased in order to provide adequate space for a landscaped buffer.

#### 5. Vehicular Access

Location of ingress and egress will be controlled and traffic circulation impacts must be carefully evaluated. The builder/developer is responsible for meeting all local city or county traffic standards. All proposed curb-cuts are subject to review and approval by the ARC. The ARC may require appropriate traffic analysis to be submitted for review.

Vehicular access should be designed to:

- minimize auto/pedestrian conflicts
- minimize curb-cuts
- maximize curb cut distance to a major intersection in an effort to minimize automobile conflicts

Shared curb-cuts between two parcels are encouraged. Driveways or curb-cuts along the curved portion of a frontage road at the intersection of a highway and a major thoroughfare is strongly discouraged.

6. Service Access and Service Areas

Service drives and service areas should not interfere with parking, driveways or walkways and must be screened from adjoining properties, all public rights-of-ways, and from the office areas of any other buildings which share the site. Ideally, service areas should be provided at the rear (side opposite the street) of all buildings. Service areas which are recessed into the buildings are preferred. These areas should be paved, internally drained and screened from public view (including views from upper floors of adjacent buildings). In all cases, screening must be compatible with building materials.

7. Outside Storage Operations

Outside storage operations are prohibited except in certain instances when deemed by the ARC to be absolutely necessary for the functioning of a service/distribution center or retail, such as a nursery. Outside overnight storage of automobiles or motorized vehicles is generally prohibited. When outside storage occurs, these activities must be screened from public view in a manner which is architecturally compatible and approved by the ARC. Towers, tanks, and other structures or equipment must be effectively shielded from public view. The location and appearance of special equipment are subject to review and approval by the ARC.

8. Pedestrian Access

Free-standing buildings are encouraged to provide pedestrian connections between immediately adjacent commercial sites or public path systems. Important connections to retail facilities, residential areas, office complexes, neighborhood greenbelts and open space should be designed into the site in low auto traffic areas and identified to users and drivers for safety. The on-site pedestrian system should be integrated with existing or future connections to adjacent sites.

Walkways for high turnover parking lots are highly encouraged. These walkways should be designed for safe access from buildings to parking areas. These walkways should be integrated with existing sidewalks and be constructed of concrete, stone, brick, tile, or other hard, slip-resistant

surface materials and be enhanced with landscaping to help distinguish and make them pleasant.

9. Minimum Parking Requirements

An adequate number of parking spaces for employees, customers/visitors, and the handicapped are required for each site. All parking spaces required to meet parking ratios must be located off street. Parking should be provided in close proximity to the building(s) being served. Parking lots should not be used by delivery or service vehicles either for parking or as the primary means of reaching service areas. At a minimum, all sites must meet the minimum parking ratios of the City of Houston Parking Ordinance or other local ordinance in effect.

10. Parking Lot Design Standards

Parking lot plans must be included with all submittals for ARC approval. Parking lots should be designed to minimize the distance between parking space and building entry for as many parking spaces as possible.

Parking lots must be constructed of concrete. A variance for the use of asphalt or decorative masonry may be granted by the ARC on a case by case basis.

All parking lots shall be designed in accordance with City of Houston standard stormwater runoff curves. All driveway connections must be built to the applicable City or County standards with a minimum turning radius of fifteen feet (15') off of local streets and twenty-five feet (25') off of major thoroughfares. Expansion and construction joints shall be located in accordance with current engineering design principles and sound construction practices.

Parking may be developed on grade, below grade, or in multi-level structures above grade. On-grade parking should appear inconspicuous, not dominate its environs, and must be visually screened from adjacent property and green space by the use of berms, new trees, and the preservation of existing trees. Entrance drives should terminate in a drop-off point at the front entrance to the building.

All parking lots should be separated from service areas and should be designed to discourage use by delivery vehicles for parking, or as the primary means of reaching service areas.

510-00-2317

High-Density Residential: Parking should be fragmented into lots of twenty to forty (20-40) spaces. Parking should occur on the interior of the site with the multi-family units oriented toward the street(s) side and side lots of the property.

Medium-Density Residential: Clustered surface parking, individual parking pads, or individual garages may be utilized in medium-density residential projects. Parking must be screened from the view of all public streets. If garages or individual pads are used for parking, separate and clustered parking must be provided for guests.

Parking should be located to provide clear and direct access to each unit. Projects which include garages and individual driveways in the front of the unit may reduce the guest parking requirement. The driveway must be a minimum of eighteen feet (18') from the front of the garage to the curb or sidewalk, whichever is closest.

#### 11. Parking Garages

For all uses, structured above-grade parking should be designed to incorporate a minimum number of levels, appear as inconspicuous as possible, and be compatible with its respective building as well as other structures on neighboring sites (concrete construction preferred). Parking structures should be no more than one-third (1/3) the height of its respective building. In general, it is recommended that parked vehicles be screened by solid spandrel panels. Cable barriers alone are discouraged. All parking structures must be internally drained, and exterior finish materials and color must be approved by the ARC.

When a parking garage is utilized, a minimum of one (1) tree at least two and one-half (2-1/2) inches in caliper and at least twelve feet (12') in height, preferably evergreen, per fifteen feet (15') of garage perimeter is required to be planted at the base of the parking garage. This is in addition to any general landscape requirements applied to the site.

Locations of entrances and exits should be planned to have the least impact on residential streets and busy intersections.

#### 12. Drainage

Internal site drainage is the responsibility of the building developer. Surface drainage to adjacent tracts is prohibited. The Municipal Utility District and

the Water Control and Improvement District in which the project is located, plus the appropriate County Flood Control District, and any and all other appropriate agencies, must inspect and approve connections to their systems when applicable. All sites must have drainage contained on site.

Surface drainage and roof run-off shall be diverted away from the building foundations, either directly to storm detention areas, storm sewers or their inlets. Drainage from open space of a building may be sheet-drained across a sidewalk to parking lot drainage points. Roof run-off must be directed to interior roof drains or to gutters and down spouts. Down spouts shall tie directly into storm sewers. All drainage must be designed by a licensed professional engineer.

13. Easements

All recorded easements and rights-of-way must be observed. Any use within the easements must have approval from the easement owner and the ARC. Additional easements for utilities service may be imposed if required.

B. Site Elements

Site elements are improvements to the site which can affect the aesthetics and visual integrity of the site as a whole. They are to be carefully considered and are subject to ARC review.

1. Utility Areas and Communication Equipment

All utility areas located outside the building must be screened from adjacent public streets and adjoining private property. Location of utilities inside the building is preferred. Banks of electric meters shall not be visible from public roadways. Towers, tanks, antennae, satellite dishes, and other structures or equipment shall be screened from adjacent public streets and adjoining private property. All transformers must be pad-mounted and screened by a wall, fence, or landscaping, and/or painted to coordinate with the adjacent building. All transformer electrical drops and utilities must be underground, including secondary power, unless specifically approved by the ARC. For roof top penetration requirements please see section C-5, Roof-top Equipment. The location and appearance of all utility and communication equipment is subject to review and approval by the ARC.

## 2. Trash Receptacles and Enclosures

Trash receptacles must be oriented to the building service areas and screened with a four-sided enclosure. The enclosure must be constructed of materials compatible with the building. The enclosure must be two feet (2') taller than the height of the receptacle and a minimum of eight feet (8') in height. Masonry construction is preferred. Gates should be constructed of metal and be opaque. Wood gates supported by a structure of tubular metal are acceptable for all uses except mid or high rise office buildings. Wood-link or chain-link materials are not acceptable for either the enclosure or the gate.

## 3. Screen Walls and Fencing

In some instances it may be necessary to provide screening between a commercial property and a neighboring commercial or residential property. When, in the judgment of the ARC, screening is required, the site developer will install a six foot (6') to eight foot (8') fence or wall along the property line. Any wall(s) or fencing must be constructed of materials which are compatible with exterior materials of the building as approved in writing by the ARC. Curb stops in parking areas are required to prevent damage to walls and fencing. The use of chain-link fencing is generally prohibited. In limited cases, the ARC may grant a variance for chain-link where the fence is not visible from the street or adjacent property. If approved, the fence must be either black or green vinyl coated.

Multi-Family Residential The common property line between multi-family residential projects of medium and high density and open space areas may be fenced. When adjacent to park space or greenbelt, fences are to be painted pipe metal or wrought-iron with a standard height of six feet (6') and a standard panel length of eight feet (8'). Spacing between pickets should be a minimum of four inches (4"). Paint finish must not conflict with the color of adjacent structures and must be rust-proof. When adjacent to non-desirable open space, such as drainage easements, the fence may be a solid fence with a maximum height of six feet (6'). The specific color and design of fences and gates must be reviewed and approved by the ARC. Rear- and side-lot fencing not facing a roadway may be opaque.

Walled or fenced courtyards are encouraged for townhouse or patio home projects. The walls of private courtyards which face public streets must be constructed of the same predominant materials as the building. Chain link fencing is prohibited.

4. Mailboxes

All mailboxes should be placed inside the building or at lighted entrances to building clusters. Mail delivery and pickup must be coordinated between the builder/developer and the U.S. Postal Service.

5. Flagpoles

A maximum of two (2) flagpoles per site will be allowed to display the U.S. Flag and the Texas flag only. School sites will be permitted one (1) additional flagpole to display the school flag. Submission for ARC review should include pole locations, flag and pole sizes.

The flagpoles should be one piece construction of seamless metal tubing or fiberglass and taper approximately one inch (1") to each five and one-half feet (5-1/2') of length. Poles should be a single architectural color such as white, clear anodized, or dark bronze finish.

The maximum height of a flagpole shall not exceed thirty-five feet (35'); the pole should be capable of withstanding local wind velocities.

The length of the flag should be approximately one-fourth (1/4) the height of the pole on which it is mounted. Building-mounted flagpoles are not permitted. Illumination of flags will be permitted for permanently mounted flags only. Flags and/or poles must be replaced when they become faded or worn.

6. Lighting

Site lighting fixtures must be installed and should provide a sense of safety and security throughout the area. Spill-over onto adjacent properties must be avoided and is prohibited where adjacent property is single family residential. All public street lighting will be installed by the local power company.

For parking lots, the light fixture luminaire should be a basic box shape with light cut-off, such as Kim EKG model or equal, mounted on a metal pole not to exceed thirty feet (30') in height or as determined appropriate by the ARC. The light color should be warm and consistent with surrounding light sources. Parking lots must be illuminated to a minimum of one (1.0) foot-candles (11 lux). Any lighting used to illuminate off-street parking areas shall be located, shielded, and directed upon the parking area in such a



510-00-2321

manner that it does not reflect or cause glare onto adjacent properties or interfere with street traffic. Figure 1

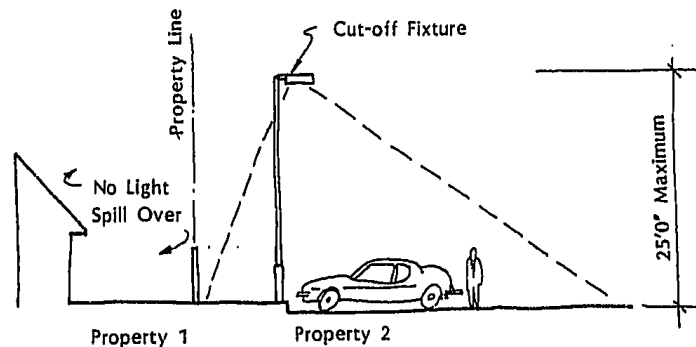

Figure 1 - Site Lighting

The light fixture luminaire for open-space and walkway fixtures should be a box or other approved design mounted on a pole not exceeding fifteen feet (15') in height. The fixture and pole color should be compatible with the building or other site lighting. Open space and walkways will be illuminated to approximately two (2.0) foot-candles (22 lux).

The use of low level lighting, landscape accent lighting and architectural lighting is encouraged. The illumination source should be a "warm light".

All light fixtures and lighting plans are subject to approval by the ARC.

#### 7. Site Furnishings / Play Equipment

Site furnishings and site architectural elements are encouraged and must be compatible in material and color with the building. Outdoor seating and gathering areas are highly encouraged. Trees in grates and planters located in and near facilities can provide a visual amenity and incorporate seating areas. All paving and tree grates should provide safe footing for pedestrians.

Exterior playground equipment requires ARC review and approval in writing prior to construction and installation. Color samples must accompany any request for consideration. Playground equipment shall not exceed twelve feet (12') in height. Multi-colored canopies are strongly discouraged. Play equipment will be substantially screened from adjacent residential uses.

#### 8. Helicopter Pads

Helicopter pads will be considered on an individual basis by the ARC and are subject to prior approval by local or federal authorities having jurisdiction.

### C. Structures

#### 1. Building Design and Character

Architectural character of buildings should be complementary to the overall image of the community. Architectural compatibility will be included in the ARC review.

Design codes of the appropriate jurisdiction must be met and, in all cases, shall meet or exceed the requirements of the City of Houston Building Code or the Standard Building Code.

Building locations should reflect consideration for roadway visibility, arcades, existing tree stands, and parking lot circulation. Buildings on corner sites should be positioned close to roadways with landscaping between the building and the adjacent street pavement.

All buildings should incorporate clean, functional design. Building mass should be simple, geometric, and finished in the same materials on all sides. Building-mounted signage, or sign bands, where necessary, should be integrated into the elevation design.

The sides and backs of buildings should be architecturally consistent with the front. Side or back elevations which are most often viewed by the general public may require as much attention as the front elevation. Roof lines, architectural detailing, and landscaping are all features that can be utilized to accomplish this objective.

Multi-tenant buildings should be constructed with compatible materials and design characteristics in order to present the identity of an organized building cluster. There should be a compatible family of design elements in building form and materials, roof lines, colors, and landscaping.

Multi-family buildings should be residential in scale and character. Balconies and wing walls for privacy are encouraged. When used, they should be part of the design and not appear as separate elements. First floor

patios must be screened by a privacy fence or wall. Carport locations and materials should complement the residential buildings.

Building height within master-planned residential communities is limited by the use and location in each community as provided for in the deed. When a site is immediately adjacent to single family residential construction, the maximum building height is limited to thirty-five (35) feet at a point twenty-five (25) feet back of the property line. The building height may increase from that point at a 1:1 ratio to a maximum height of sixty (60) feet.

Figure 2

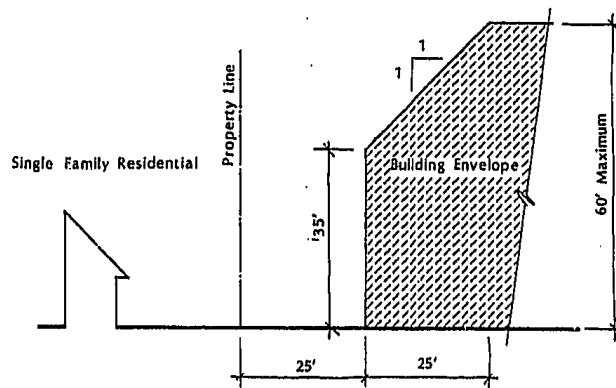

Figure 2 - Building Height

2. Energy Conservation

Energy conservation should be a factor in building design. Energy-conscious design should include building siting, exterior building envelopes, energy-efficient heating, ventilating, air conditioning, water heating, illuminating systems, and other equipment for effective use of energy.

Energy conservation should consider the following:

- Number of stories.
- Exterior surface colors.
- Shading or reflections from adjacent structures, surrounding surfaces or vegetation.
- Opportunities for natural ventilation responding to prevalent wind direction.
- Adequate thermal resistance and low air leakage.

### 3. Exterior Materials and Colors

All exterior materials should complement the architectural design and the overall image of the community in which it is located. Buildings should be constructed with compatible materials, textures, colors, and forms. No more than two (2) dominant materials should be used on a building exterior.

Acceptable materials are concrete, concrete block, glass, glass block, brick, split face concrete block, stone, wood, metal, stucco and stucco-like materials. Current technology should be considered in construction material selections, i.e., use of energy-conserving glass. Corrugated steel or aluminum siding, industrial building systems, and plastic are some of the materials generally prohibited from use unless approved by the ARC for a site location not visible from the public street or adjacent sites.

Earth-tones with limited pastel alternatives are recommended for dominant wall colors for building materials. An accent color may be applied to trim, fascia boards, door panels, or miscellaneous metals. All colors are subject to ARC review and approval.

### 4. Roof Design and Materials

Roof forms and materials on all buildings within immediate proximity should be compatible with one another to create the image of an ensemble. Pedestrian arcades, canopies, and overhangs should be integrated with the roof form. Roof color should be uniform and integral to the materials. Earth-tones such as grey, green, beige, red or brown are acceptable. Acceptable materials include asphalt shingle, wood simulated composition, slate, metal, and built-up or single-ply membrane.

### 5. Roof-top Equipment

Roof-top penetrations and mechanical equipment must be completely screened from view from public streets and neighboring parcels by a parapet wall. The parapet wall must be compatible with building materials. Roof-top equipment must be painted to blend with the color of the building or the roofing system when visible from adjacent parcels or buildings. Figure 3

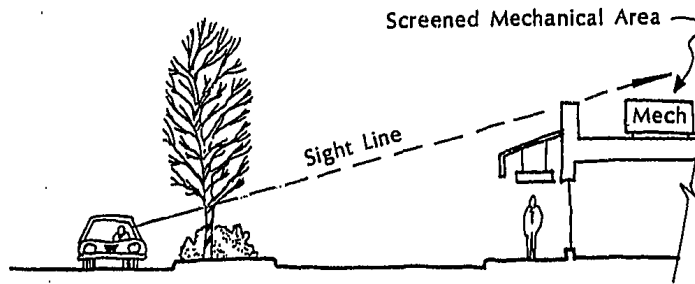

Figure 3 - Roof-top Equipment

6. Pedestrian Arcades

Pedestrian arcades and covered walkways are encouraged and should be incorporated to link adjacent buildings. Arcades and canopies create identity and provide shade.

7. Awnings

Awnings that serve a functional purpose and are compatible with the building forms are acceptable. Awnings may be installed over openings such as doorways, windows, recessed openings and archways. The use of angled or "lean-to" type awnings are preferred over other configurations. Awnings are recommended to be one solid color. Multicolor and/or striped awnings are discouraged.

Awnings may be constructed of canvas and metal. The frame must be securely attached to the building and finished in a non-corroding surface. The individual width of an awning should not exceed the width of the opening for which it is intended. The height of an awning shall be limited to not more than one-half (1/2) the height of the opening for which it is intended. Awnings must be replaced when they become faded or worn. No graphics are permitted on an awning in a multi-tenant retail center due to the inconsistent coloration that may result as awnings are replaced in a piecemeal fashion when tenants vacate their space. Logo graphics (no text) may be permitted on awnings for freestanding retail buildings at the discretion of the ARC. Figure 4

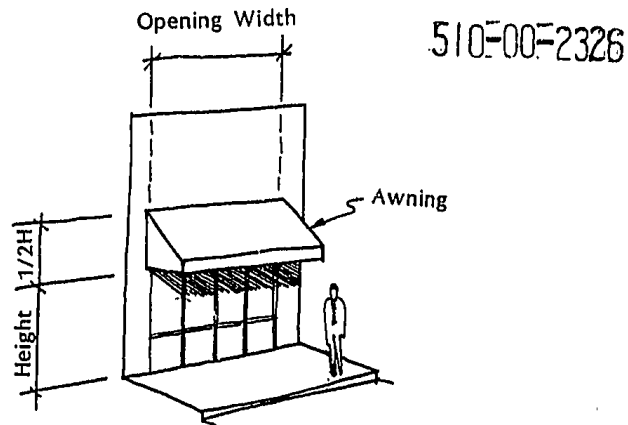

Figure 4 - Awnings

#### 8. Burglar Bars

Wrought iron and/or burglar bars will be considered only if the ARC determines that they are compatible with the architectural character of the building. Burglar bars on the exterior are prohibited. When approved, burglar bars must be attached to the inside of the window frame behind the glass. Approval must be granted prior to installation.

#### D. Signage

All non-residential uses must conform to the signage requirements outlined below unless specified otherwise by additional requirements outlined in the community-specific guidelines contained in Appendix C. Whenever a question arises, the order of governance shall be the requirements outlined in the community-specific Guidelines and then the general requirements listed below.

In general, it is prohibited to use signage which by its location, size, shape, color, lighting, subject or sound, may be harmful to the appearance of the locality, public street, site, or view, or constitute a threat to road traffic. Specifically prohibited signs include those signs prohibited in the City of Houston Signage Ordinance, as well as rotating, trailer, animated, movable, oscillating, iridescent or dayglo painted signs, signs which make noise, and laser lights. Also prohibited are "canned" signs constructed of a light box frame with a single panel backlit sign which includes the logo and sign copy applied to the building surface (except

for national tenants of freestanding retail buildings as may be approved by the ARC). Other prohibited signs include changeable message boards (with the exception of community and or informational signs for schools, churches and institutional buildings subject to ARC approval). Banners and flags are prohibited except as permitted in these Guidelines. Balloons, streamers, pennants, search lights, signs with exposed or flashing lights, signs with moveable parts, or any other such fixtures or items deemed to be inconsistent with the intent of these Guidelines are prohibited. The use of exposed neon is discouraged and not acceptable in most cases subject to ARC approval. No sign will be permitted to extend beyond the roof line of the building(s).

All sign designs are subject to approval by the ARC. Detailed plans and specifications of any sign must be submitted for review prior to installation. All signs must be fabricated and installed in compliance with all applicable codes and ordinances established by the City of Houston or other appropriate governmental agencies.

All permitted signs will fall into one of the following categories defined in this section:

1. Special Purpose Signs
2. Ground-Mounted Monument - Highway Location
3. Ground-Mounted Monument - Non-Highway Location
4. Building-Mounted Signs
5. Building and Unit Address
6. Under Canopy - Retail
7. Window Signs
8. Directional and Delivery Signs
9. Reserved and Visitor Parking Space Signs
10. Regulatory Signs
11. Exterior Directories
12. Construction Signs
13. Leasing/For Sale Signs
14. Promotional Signs
15. Outdoor Displays

**Sign definitions are as follows:**

1. Special Purpose Signs

Any special purpose or unique sign not covered elsewhere in this section and which may have a potential public visual impact on a site must be reviewed and approved by the ARC.

## 2. Ground-Mounted Monument - Highway Location

This section provides information and restrictions governing signage for sites located on the frontage road of a limited access interstate highway, or freeway such as I-45, I-59 or US 290.

### a. Form

Ground-mounted signs typically consist of two parts: a base and a message area.

### b. Quantity

Each site will be allowed one (1) ground-mounted sign.

#### Exceptions:

Auto dealers will be permitted one ground-mounted pylon sign in lieu of the ground-mounted sign.

### c. Dimensions

#### Type A:

Retail shopping centers, theaters and other uses, as determined appropriate by the ARC, will be allowed a ground-mounted monument sign with a maximum height of twenty feet (20'), including a base with a minimum height of one foot six inches (1'6"), a maximum sign width of sixteen feet (16') and a maximum sign depth of two feet (2'). Where natural topography requires, the height of the sign base at one end may be increased up to five feet (5') at the discretion of the ARC. See Figure 5

#### Type B:

Freestanding retail, restaurants, entertainment (arcades, bowling alleys, etc.), service stations, hotels, office buildings and other uses, as determined appropriate by the ARC, will be allowed a ground-mounted monument sign with a maximum height of ten feet (10'), including a base with a minimum height of six inches (6"), a maximum width of sixteen feet (16') and a maximum sign depth of two feet (2'). See Figure 6



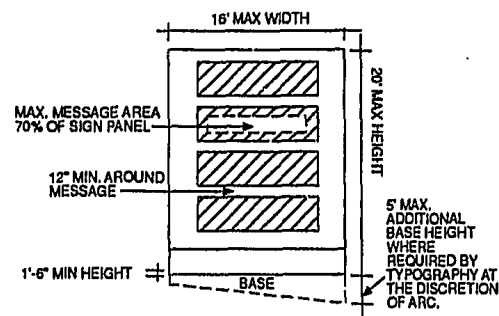

Figure 5 - Type A Ground-Mounted Monument Highway Location

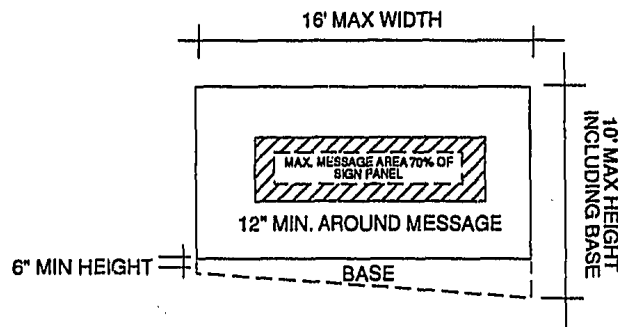

Figure 6 - Type B Ground-Mounted Monument Highway Location

Theaters will be permitted to include one (1) changeable message marquee as a part of a ground-mounted sign at a highway location.

Auto dealer pylon signs are limited to a maximum height of forty-five (45) feet from natural grade with a maximum sign area of two hundred (200) square feet including name and logo.

d. Materials

A ground-mounted sign must be constructed of materials architecturally compatible with the exterior building finish and landscaping theme.

Acceptable materials are aluminum, wood, porcelain enamel, brick/split face concrete block, tile and stucco. Letters may be pin mounted, three dimensionally sculpted or part of an opaque panel with translucent graphics.

e. Color

For ground-mounted signs, the color of the face may vary but should relate to architectural features of the buildings the sign is identifying. The sign background should be a medium to dark range color with the message area lettering in white. A maximum of three (3) colors, including white, is permitted. The use of a national logo may be permitted subject to ARC approval.

f. Layout

Ground-mounted signs should be double faced. Each face of a sign must be identical. The letters, logo or message area may not cover more than 70% of the length or height of the sign face. A street address (numbers only) must be included on this sign face or base and is exempt from the 70% sign coverage restriction.

The building name and up to three (3) tenant names may be identified on sign type "A". For ease of visibility and tenant turnover, the name of the building or a single tenant name is permitted on sign type "B".

Advertising information such as slogans, services, hours of operation, telephone number, etc. are prohibited except for emergency public health and safety facilities such as emergency clinics, full service hospitals, police stations, etc., which may display emergency hours if applicable.

g. Illumination

Monument signs should be internally illuminated or backlighted. Internally illuminated sign panels must have an opaque field with only the type and graphics translucent. For non-internally illuminated signs, ground lighting should evenly wash the entire face of the sign and these fixtures should be screened within the landscape treatment and protected from mowing and landscape maintenance equipment. Lighting fixtures should be inconspicuous and approved by the ARC prior to installation. All ballasts, wiring, transformers, starters, and

other necessary equipment must be concealed and protected from mowing and landscape maintenance equipment.

h. Placement

Ground-mounted monument signs must be located perpendicular to and outside the public rights-of-way. Care should be taken to preserve sight lines for motorists at all driveway and intersection locations.

i. Landscaping

The installation and maintenance of landscape treatment around the base of a ground-mounted sign is required. A list of recommended planting material is found in Appendix A. Grass, ground cover, seasonal flowers, or shrubs are acceptable.

3. Ground-Mounted Monument - Non-Highway Location

a. Form

Ground-mounted signs typically consist of two parts: a base and a message area.

b. Quantity

Each site will be allowed one (1) ground-mounted sign. For sites facing two major thoroughfares, consideration will be given for a second ground-mounted sign. One additional sign, for retail centers with a minimum of 75,000 square feet of leasable area, may be provided to identify a maximum of two anchor tenants not previously identified by the ground-mounted signs. An anchor tenant is defined as a tenant with a prominent location in the center, typically 5,000-10,000 square feet or greater leasable area, and regional name recognition. In addition, single user pad site buildings will be entitled to a sign (even when the pad site is created out of an existing larger parcel) if the pad site has significant frontage ( $\pm$  200 ft.) on the adjacent major thoroughfare.

c. Dimensions

The maximum height of a ground-mounted sign is five feet (5') including a base with a minimum height of six inches (6"). The

maximum sign area may not exceed thirty-six (36) square feet. The base of the ground-mounted sign should not be more than one foot (1') higher than the elevation from the top of the curb found nearest the sign location. Sign depth should not exceed two feet (2').

Exceptions:

Office buildings with more than one hundred thousand (100,000) square feet of leasable area may increase the maximum area of the ground-mounted monument sign to sixty (60) square feet.

Theaters will be permitted to include one (1) changeable message marquee as a part of a ground-mounted sign at a non-highway location or a building-mounted sign. A second changeable message marquee may be considered by the ARC when the site is located at the intersection of two major thoroughfares. Theaters which include a changeable message marquee may increase the size of the sign to one hundred and twenty (120) square feet with a maximum height of eight feet (8') including a six inch (6") base.

d. Materials

A ground-mounted sign must be constructed of materials architecturally compatible with the exterior building finish and landscaping theme. Acceptable materials are aluminum, wood, porcelain enamel, brick/split face concrete block, tile and stucco. Letters may be pin mounted, three dimensionally sculpted, or part of an opaque panel with translucent graphics.

e. Color

For ground-mounted monument signs, the color of the sign surface must be the same for all users and should relate to architectural features of the buildings the sign is identifying. It is recommended the sign background be a medium to dark range color with the message area lettering in white for visibility. All user names must be the same color. A maximum of three (3) colors, including white, is permitted. The use of a national logo may be permitted subject to ARC approval.

f. Layout

Ground mounted monument signs should be double faced. It is recommended, but not required that each side of a sign be identical.

Only one street address (numbers only) must be included on the sign face or base. The following criteria should guide sign layout.

**Intent:** One single user or project identification per sign.

**For retail** projects where identity for more than one user is required, a maximum of two (2) user names, with a maximum of four (4) lines of copy is permitted on the sign face. Older areas of Clear Lake City and Copperfield may differ from this requirement. New projects in these areas will be judged on a case by case basis by the ARC. Figure 7

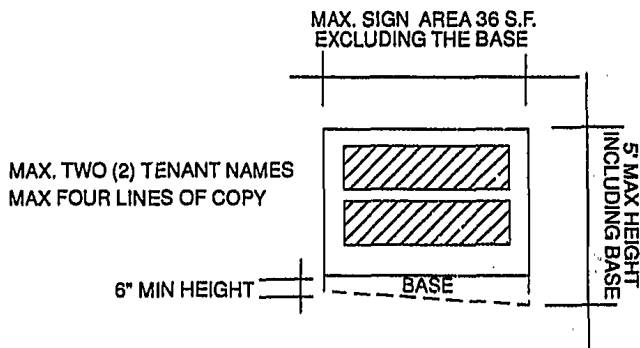

Figure 7 - Retail Ground-Mounted Monument Non-Highway Location

**Office** building tenants are not permitted exterior identification except in the form of the ground-mounted sign, therefore, office building ground-mounted signs may include the building name and up to four (4) tenant names with a maximum of four (4) lines of copy. It is recommended for ease of visibility and for tenant turnover that a maximum of two (2) tenants be identified on this type of sign. See Figure 8

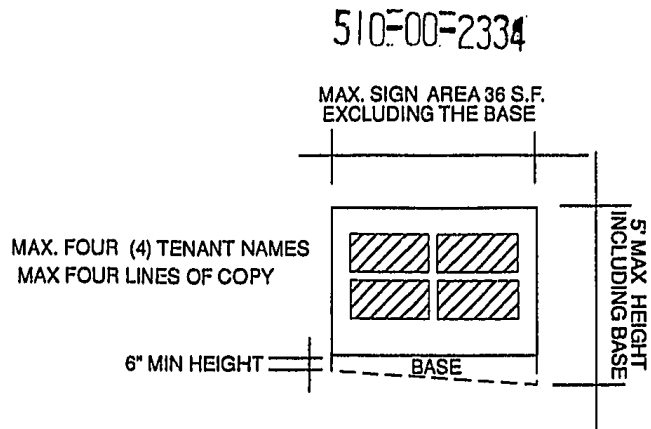

Figure 8 - Office Building Ground-Mounted Monument Non-Highway Location

Service stations may include the company logo, name, and fuel price information. Absolutely no other advertising may be included on the sign. Additional copy will be considered for services - such as a car wash, auto repair, or convenience shop.

Hotels may include the name of the hotel and logo.

Schools may indicate the institution's name, address and logo. In addition, a changeable message area may be incorporated into this sign and occupy up to two-thirds (2/3) of the allowable area on each side. The changeable message area must be fully protected within a case. Letters should be white on a dark background for visibility.

Churches may include the name of the church and the name of one pastor. In addition, a changeable message area may be incorporated into this sign and occupy up to two-thirds (2/3) of the allowable area on each side. The changeable message area must be fully protected within a case. Letters should be white on a dark background for visibility.

Multi-family residential projects may include the project name and project logo.

Text: User names may be stacked or put side by side.

Color: The entire sign face must be one color. All user names must be the same color.

**Letter Height:** If four (4) equal lines of copy are used, maximum letter height is eight (8) inches.

**Clarity:** The sign must be visually uncluttered. The names should be evenly spaced and centered on the sign face. There should be an uninterrupted space along all edges of the sign of approximately six (6) inches. Within one line of type the same size type must be used. When two users are identified on the same sign face, there should be a minimum of three to four inches (3-4") visual separation between the two to facilitate readability.

**Advertising:** Advertising information such as slogans, services, hours of operation, telephone number, etc. are prohibited except for emergency public health and safety facilities such as emergency clinics, full service hospitals, police stations, etc., which may display emergency hours if applicable.

g. Illumination

Monument signs should be internally illuminated or backlighted. Internally illuminated sign panels must have an opaque field with only the type and graphics translucent. For non-internally illuminated signs, ground lighting should evenly wash the entire face of the sign. Lighting fixtures should be inconspicuous and approved by the ARC prior to installation. All ballasts, wiring, transformers, starters, and other necessary equipment must be concealed. Lighting fixtures should be protected from mower and other landscape maintenance equipment.

h. Placement

Ground-mounted monument signs must be located perpendicular to and outside the public right-of-way. Care should be taken to preserve sight lines for motorists at all driveway and intersection locations.

i. Landscaping

The installation and maintenance of landscape treatment around the base of a ground-mounted sign is required. A list of recommended planting material is found in Appendix A. Grass, ground cover, seasonal flowers, or shrubs are acceptable.

510-00-2336

4. Building-Mounted Signs

For use with retail and commercial buildings, schools, hospitals, and churches only. Office buildings are not permitted building-mounted signs.

For multi-tenant facilities or retail centers, a comprehensive signage program must be developed for the project and submitted to the ARC for approval prior to sign fabrication. All building-mounted signs within a single project must be of the same fabrication technique. It is the responsibility of the property owner/manager to enforce the signage program.

## a. Form

Building-mounted signs consist of a message area in either a graphic band or band which is integrated into the facade of the building or individual fascia-mounted signs extending along the facade of the building. Building-mounted identification must be individual letters and logos. No "canned" signs are permitted as outlined in the introductory paragraphs of Section D - Signage.

## b. Quantity

Multi-tenant retail and commercial centers will be allowed one (1) building-mounted sign for each retail tenant. For retail tenants with two or more major exposures, such as at building ends facing major thoroughfares, consideration will be given for an additional sign.

Multi-family residential projects will be limited to one (1) building-mounted sign identifying the leasing or sales office only.

Schools will be allowed one (1) building-mounted sign to identify the name of the school.

Churches will be allowed one (1) building-mounted sign to identify the name of the church. This sign must be incorporated into the design of the building architecture i.e., a plaque or inlay.

Service Stations will be allowed two (2) canopy-mounted signs (brand name and/or logo), one (1) building-mounted sign to identify the convenience/foodstore, and one (1) building-mounted sign to identify a car wash. "Full Service/Self Service" signs and brand logos will be mounted on the column of the canopy or the pump top.



510-00-2337

## c. Dimensions

In general, building-mounted signs shall be in scale with the facade of the building. If a graphic band is used on a multi-tenant retail or commercial building, the band may not exceed forty-eight inches (48") in height. Sign length for individual retail or business park tenants is limited to a maximum of seventy (70) percent of the width of the wall or tenant space on which the sign is mounted. The total sign-to-building area relationship will be evaluated by the ARC.

Exceptions:

Service Station canopy-mounted signs are limited to a maximum length of 33% of the side of the canopy to which it is mounted.

Theaters will be permitted to include one (1) changeable message marquee as part of either a ground-mounted sign at a non-highway location or a building-mounted sign. Consideration of a second changeable message marquee may be considered by the ARC when the site is located at the intersection of two major thoroughfares.

Theater signs which include a changeable message marquee are limited to a maximum sign area of one hundred and twenty (120) square feet.

## d. Materials

The same fabrication methods and materials must be used for all signs within a single development. Building-mounted signs may be constructed of individual pin-mounted letters, individual fascia-mounted signs, internally illuminated channel letters with opaque metal sides, or an internally illuminated opaque sign band with illuminated cut out letters and graphics.

## e. Color

Building-mounted signs in a single project must be of one (1) color combination and compatible with the exterior building colors. If a graphic band is used, the background color must remain consistent. Placement of a logo-type symbol which varies from the established fascia color may be considered on a case-by-case basis for retailers with national logo identities. Logo color may vary but the color of the logo-type sign must be reasonably compatible with the established color

for the project and with the color of other signs in the project. Colors will not be permitted when judged by the ARC to be in conflict with the building materials or other signs.

f. Layout

Building-mounted signs will typically have one line of copy. For most uses, the letter and logo height is restricted to a maximum of twenty-four inches (24"). If the length of an individual tenant name requires two lines of copy, each line shall be a maximum height of fifteen inches (15") with a six inch (6") space between the lines. A maximum of two (2) lines of copy shall be permitted for a total maximum height of thirty-six inches (36"). Special consideration may be given at the discretion of the ARC to lettering and logo heights of anchor retailers who occupy more than twenty-five thousand (25,000) square feet or freestanding facilities on the frontage road of a limited access highway or freeway.

Multi-family residential and churches shall limit letter height to a maximum of twelve (12) inches.

Building-mounted signs must be centered around a common horizontal band on the front of the building. No sign shall be allowed to extend beyond the roof line of the building.

g. Illumination

Building-mounted signs may be constructed of individually mounted metal letters back lit or halo lit. These signs may be externally lit with ground- or building-mounted fixtures provided the lighting source is discretely hidden from public view. Internally illuminated channel letters with a flat translucent Plexiglas face are also acceptable. All signs in a single development must be illuminated in the same manner.

Exposed tube graphics where the light source is neon or other gas in a tube which is bent to form letters, symbols and shapes is permitted only upon special approval of the ARC for freestanding retail locations. Tube letters should not be multiple tube widths due to the intensity of the colors created. Simple tube width letters will be considered. Tube graphics which create continuous accent strips or stripes on a building exterior are not allowed.

510-00-2339-29

Multi-family residential project signs may not be internally illuminated.

h. Placement

For building-mounted signs, no sign shall be allowed below the fascia with the exception of under canopy signs in retail centers as outlined in section D-6. Additionally, no sign shall extend above the roof line of a building. Signs on the rear of any building will be allowed only if the building's rear faces the public street(s), and they are approved by the ARC.

Church signs should be located at the building entrance and may not be placed above the first floor level.

5. Building and Unit Address

Office buildings will be allowed one (1) building-mounted address consisting of the address numerals only. Numerals must be individually mounted on the building near the entry. The numerals may not be installed above the first floor of the building. Height is restricted to a maximum of twenty-four inches (24"). All numerals shall be installed in a horizontal manner and maintain a plumb relationship to the bottom line.

For multi-family projects, the building address numbers are limited to a maximum height of twelve inches (12").

6. Under Canopy - Retail

Shopping Center designs may provide for covered walkways, arcades, awnings, or other fascia treatments which obscure the building-mounted tenants signs from pedestrian view. For this reason, individual tenant pedestrian signs are permitted.

a. Form

Plaques with identical information on two (2) sides.

b. Quantity

One (1) sign per tenant or store is permitted.

## c. Dimensions

These signs must be a common size for all stores in the center and may not exceed eight (8) square feet.

## d. Materials

These signs should be compatible with the architecture and related to the building identification signs.

## e. Layout

These signs may display the tenant name and logo only. No descriptive or advertising copy is allowed. A standard program shall be developed for each center defining layout, color, typography, logo, and graphic devices. Individuality in these signs is permissible within the context of a sign program that has been approved by the ARC.

## f. Placement

These signs are suspended from the walkway covering perpendicular to the store front or mounted on the store front in areas approved by the ARC. The bottom of the sign must be a minimum of eight feet (8') above the sidewalk.

7. Window SignsOffice Buildings:

Window graphics such as name, hours of operation, telephone number, address, advertising information, etc., are not permitted on the building exterior for individual tenants of a multi-tenant building with a common entrance.

Retail and Commercial Buildings:

When retail or commercial tenants have separate exterior entries, they shall be allowed to identify the name of the tenant, emergency telephone number, numerical street address, hours of operation and small logo on the door or immediately adjacent to the separate entry. The advertising of services of any kind is strictly prohibited. All other glass areas shall remain free of graphics.

When permanent window graphics are desired, the landlord must include window graphics criteria as a part of the comprehensive signage program submitted to the ARC for approval. Window graphics criteria must include a consistent color (white, black or gold is recommended) and a consistent location. The type style used to identify the tenant on the window should match the type style of the building-mounted sign. The maximum letter height permitted to identify the tenant name shall be limited to four inches (4"). The maximum letter height permitted for all other information is two inches (2"). Window graphics should not occupy more than ten percent (10%) of the window area in which it is displayed.

Temporary promotional window graphics should be a simple tasteful design and should not occupy more than ten percent (10%) of the window area in which it is displayed. In no case shall a temporary graphic be placed on the exterior of the window.

There may be no illuminated or large signs behind glass areas which advertise on a permanent basis. Neon "open" signs are permitted behind the front glass.

8. Directional and Delivery Signs

These signs direct and control the movement of vehicular traffic within a site. The design shall consist of a simple one (1) or two (2) post and panel system. The posts and panels must be painted galvanized steel or aluminum. The color must be compatible with the building and other site and building signage. The message must be succinct and letters must be white adhesive and reflective material. These signs will be low profile signs which may not be taller than two feet (2') or wider than four feet (4'). Overall height of the sign from ground level shall not exceed four feet (4'). Maximum sign area is four (4) square feet.

The number of directional signs should be kept to a minimum. Sign location, color, size, and message are subject to ARC approval. These signs are not allowed in the landscape reserves adjacent to the street.

9. Reserved and Visitor Parking Space Signs

Designated parking space signs, other than ADA Guideline handicap or disabled parking signs are allowed in the form of bumper stops or free-standing signs.

510-00-2342

Retail buildings and retail centers are restricted to the use of bumper or curb stops with the message limited to the length of parking time allowed i.e. "15 minute parking". The name of a particular tenant is not allowed.

For office buildings the use of bumper stops or curbs or freestanding ground-mounted signs may be used. Bumper stops or curb stops may be painted with either "RESERVED" or "VISITOR". The name of a particular tenant is not allowed. The letters must be painted on a white background. Maximum letter height is limited to four inches (4").

Free-standing ground-mounted signs may be painted with the message "VISITOR PARKING" or "RESERVED PARKING". All free-standing parking signs shall be aluminum construction attached to a single post fabricated from either round or square aluminum tubing. Maximum sign size shall be twelve inches by eighteen inches (12" x 18"). The sign shall be set in concrete.

The color of parking signs shall match the visual intent of other building and site signage and shall harmonize with the environment. The sign shall be in a medium range color with lettering in white or beige. Polyurethane (gloss) enamels shall be used throughout. No more than two (2) colors may be used, including the typography. Both the rear surface and post shall be painted the sign color or black to blend the sign into the environment. No sign shall exceed four feet six inches (4'6") in total height (sign and post). It shall be set back a minimum of two feet six inches to four feet six inches (2'6"-4'6") from the curb and centered within the applicable parking space. Typography shall be Helvetica Medium.

10. Regulatory Signs

All traffic control and regulatory signs should be governmental standard.

11. Exterior Directories

Generally, tenant directories are to be located inside the building structure. However, for small professional office buildings with a common entrance under fifty thousand (50,000) square feet of gross leasable area and churches, one (1) ground-mounted exterior directory near the building entrance or adjacent to the parking lot with the message area not visible from the public right-of-way will be permitted. Design drawings and location shall be submitted for ARC review and approval before installation.

These signs shall be compatible with the architecture, landscape, and other sign elements of the building. They must be constructed of quality materials.

Approved lettering methods include silk-screen, vinyl die cut, or incised aluminum panel filled with Plexiglas. The sign must have a dark background with white type. Logos are not permitted. Maximum sign area permitted is six (6) square feet.

Office building exterior directories include the name of the building, tenant name and suite number. The name of the management company and telephone number may also be included.

## 12. Construction Signs

The developer of each site may install one (1) temporary, free-standing sign for information pertinent to a site and its stage of development. This sign should succinctly communicate information and be devoid of visual clutter. It is recommended that the street address to be displayed prominently on this sign to guide construction traffic. When the construction entry is not within close proximity to the construction sign, a small separate temporary sign may be used to display the street address so long as the sign is of similar quality and construction.

A sign may be erected on a site after the site has been purchased. Information may be added or the sign may be exchanged for another to indicate the advent of construction or to recruit employees. Each revision or sign replacement must conform to the following criteria and be approved by the ARC prior to installation. A sign that is to be replaced with another must be removed before the other sign can be installed. Construction signs must be removed from the site within fifteen (15) days of occupancy or the installation of the "Leasing/For Sale" sign. The construction sign is to be designed in accordance with the guidelines provided below and approved by the ARC prior to its installation on the site.

### a. Dimension

Construction signs may be a maximum of fifty (50) square feet in area for projects under eighty thousand (80,000) square feet of building area. For projects larger than eighty thousand (80,000) square feet of building area, the sign may be up to a maximum of one hundred (100)

square feet. The maximum overall height for a temporary construction sign is limited to ten feet (10').

Special consideration may be given for larger signs when facing a highway. Allowable dimensions will depend upon the relative scale of surrounding features, the velocity of traffic along the highway and the distance and/or elevation from same.

b. Layout

A temporary construction sign may contain no more than the following information:

- Name of the Project
- Address of the Project
- Leasing Agent and Telephone Number
- Size/Use of Project
- Contractors
- Architect
- Other Consultant(s)
- Lender
- Completion or Opening Date

c. Materials

All temporary site information signs will be designed to last the length of their intended use without significant fading, peeling, blistering, warping, cracking or rotting. Signs must be constructed of wood, fiberglass, or aluminum. Signs must be boxed and all panel edges must be properly sealed for weather protection. All exposed surfaces and edges must be primed and painted. All fasteners are to be non-corrosive nails or screws. All posts should be of sufficient strength and durability to withstand local wind loads and remain stable throughout the duration of the construction period. All footings should extend four feet (4') below grade in sharp sand or compacted earth.

The ARC reserves the right, without liability, to cause removal of any sign deemed to be in violation of this provision by virtue of deterioration or damage.



510-00-<sup>H-35</sup>2345

d. Color

The copy on any temporary sign is recommended to be white with a dark background color such as dark grey, dark blue, etc.

e. Placement

All temporary signs shall be parallel to the street and located inside of the property line, behind any setback which affects the parcel. The location and installation of temporary signs must not harm existing trees or their roots.

13. Leasing / For Sale Signs

The builder/developer may install one temporary, free-standing Leasing/For Sale sign for information pertinent to a site. The sign may be erected on a site after the site has been purchased or when construction is completed and the temporary construction sign has been removed. This sign should succinctly communicate information and be devoid of visual clutter. This sign is to be approved by the ARC prior to its installation on the site. No temporary promotional signs (including trailer signs) are allowed on the premises or adjoining public street rights-of-way.

Each revision or sign replacement must conform to the following criteria and be approved by the ARC. A sign that is to be replaced must be removed before a new sign may be installed. Leasing/For Sale signs must be removed from the site when the project is ninety percent (90%) leased. After that point, retail projects may display Leasing/For Sale information inside the window of the space available for Leasing/For Sale.

a. Dimension

Leasing/For Sale signs may be a maximum size of twenty-five (25) square feet for projects under eighty thousand (80,000) square feet of building area. For projects larger than eighty thousand (80,000) square feet of building area, the sign may be a maximum of thirty-two (32) square feet. A Leasing/For Sale sign is limited to a maximum height of four feet six inches (4'6").

Special consideration may be given for larger signs when facing a highway. Allowable dimensions will depend upon the relative scale of

surrounding features, the velocity of traffic along the highway and the distance and/or elevation from same.

b. Layout

A Leasing/For Sale sign may include only the name of the leasing agent and respective logo, a telephone number, and either "For Leasing Information" or "For Sale".

c. Materials

All temporary site information signs will be designed to last the length of their intended use without significant fading, peeling, blistering, warping, cracking or rotting. Signs must be constructed of wood, fiberglass, or aluminum. Signs must be boxed and all panel edges must be properly sealed for weather protection. All exposed surfaces and edges must be primed and painted. All fasteners are to be non-corrosive nails or screws. All posts should be of sufficient strength and durability to withstand local wind loads and remain stable throughout the duration of the construction period. All footings should extend four feet (4') below grade in sharp sand or compacted earth.

The ARC reserves the right, without liability, to cause removal of any sign deemed to be in violation of this provision by virtue of deterioration or damage.

d. Color

The copy on any temporary sign is recommended to be white with a dark background color such as dark grey, dark blue, etc.

e. Placement

All temporary signs shall be parallel to the street and located inside of the property line and behind any setback which affects the parcel. The location and installation of temporary signs must not harm existing trees or their roots.

14. Promotions

510E00E2347

a. Promotional/Special Events

Notification of all proposed promotions must be given to the ARC in writing. Receipt of ARC approval in writing is required prior to the promotion. Notification must include:

- type of promotion
- dates involved
- temporary construction(s) to be utilized during the campaigns

Promotional items may be utilized for the promotional period only. Promotional campaigns and special events may be held by a free-standing retail establishment or retail center for a maximum period of sixteen (16) consecutive days, four (4) times a year. One of those four (4) events may be increased to thirty (30) days if the promotion occurs during the Thanksgiving to Christmas sales season. Churches and/or community organizations may be permitted the use of a banner once per year for a period of sixteen (16) days duration.

Should a tenant of a retail center plan a special event, the owner/property management must advise the ARC of the event on behalf of that tenant. If only a single tenant has a promotion, this event will count as one of the four promotions for the entire retail center.

Service Station promotional graphics and merchandise displays are strongly discouraged. When they are used, however, they must be contained under the canopy area or against one designated building wall.

b. Banner SignsPromotional:

Banners may be used during a promotion/special event for a church once per year for a period of sixteen (16) consecutive days. Banners may also be used as temporary identification if proof is furnished to the ARC in writing that a permanent sign, which was previously approved by the ARC, has been ordered.

Banners used for temporary identification must meet dimension, lettering and layout requirements for building-mounted signs and should be securely fastened on all four (4) corners to the fascia. If the banner meets these conditions it will be permitted for a period not to exceed thirty (30) days. The banners will be permitted for identification purposes only and should display the name of the facility or an abbreviation of that name.

Banners intended for advertising purposes such as Grand Opening, Open Now sales and advertising slogans are prohibited.

Community Identity:

Street banners are special graphic elements that depend on good design. Banners may be displayed only in specially designated town center or community center areas upon ARC approval of an overall program. This type of banner may be displayed from street light standards or special free standing banner standards only.

15. Outdoor Displays

Temporary outdoor displays of merchandise are prohibited from all retail operations with the exception of hardware stores or major anchor retailers. Outdoor display is limited to "outdoor use" items only, i.e., lawn mowers, wheel barrows, tillers, barbecue grills, bags of mulch, etc. It is recommended that this area be defined by low fences or walls, trellis, etc. Merchandise may not cover more than half the width of the pedestrian walkway between the store front and the curb. All clearances must conform to ADA requirements.

510-00-2349

**III. Appendix A**

**A. Landscape Installation**

1. **Landscape Edges:** Landscape edges shall separate all grass areas from shrub, groundcover, and mulch areas. Recommended separation methods include redwood, concrete, steel, landscape timbers, or brick.
2. **Accent Treatments:** Accent treatments for landscaped planting beds such as shredded pine bark mulch or river rock are encouraged.

**B. Recommended Landscape Planting List**

**1. Street Trees/Parking Lot Trees/Background Trees**

<u>Botanical Name</u>	<u>Common Name</u>	<u>Recommended Size Min*</u>
Carya Illinoensis	Pecan	3" cal. (container grown)
Koelreuteria Apiculata	Golden Raintree	15 gal.
Lagerstroemia Indica	Crepe Myrtle Multi or Std.	15 gal.
Liquidambar Stryaciflua	American Sweetgum	15 gal.
Magnolia Grandiflora	Southern Magnolia	15 gal.
Platanus Mexicana	Mexican Sycamore	3" cal. (container grown)
Pinus Caribaea	Slash Pine	3" cal. (container grown)
Pinus Talda	Loblolly Pine	3" cal. (container grown)
Quercus Falcata	Southern Red Oak	3" cal. (container grown)
Quercus Shumardii	Shumard Oak	3" cal. (container grown)
Quercus Nigra	Water Oak	3" cal. (container grown)
Quercus Phellos	Willow Oak	3" cal. (container grown)
Quercus Virginiana	Live Oak	3" cal. (container grown)
Ulmus Parvifolia 'Sempevirens'	Drake Elm	3" cal. (container grown)
Fraxinus Pennsylvanica	Green Ash	3" cal. (container grown)
Pyrus Calleryana	Bradford Callery Pear	3" cal. (container grown)

**2. Accent Trees/Group Planting/Plazas**

<u>Botanical Name</u>	<u>Common Name</u>	<u>Recommended Size Min*</u>
Betula Nigra	River Birch	2.5" cal.
Cercis Canadensis	Eastern Redbud	15 gal.
Crataegus Marshallii	Parley Hawthorn	15 gal.
Gleditsia Triacanthos	Honey Locust	2" cal.
Ilex Cassine	Dahoon Holly	6' ht.
Ilex Decidua	Deciduous Holly	6' ht.
Ilex Opaca	American Holly	8' ht.
Ilex Vomitoria	Yaupon	6' ht.
Lagerstroemia Indica	Crepe Myrtle	30 gal.
Lagustrum Texanum	Wax Leaf Lagustrum	7' ht.
Magnolia Soulangeana	Saucer Magnolia	15 gal.

2. Accent Trees/Group Planting/Plaza Con't

Olea Europaea	Olive (Mission)	15 gal.
Pinus Thunbergi	Black Japanese Pine	15 gal.
Plantanus Occidentalis	Sycamore	1.5" cal.
Podocarpus Macrophylla	Yew Podocarpus	15 gal.
Prunus Caroliniana	Cherry Laurel	15 gal.
Pyrus Calleryana	Bradford Callery Pear	30 gal.
Pyrus Kawakami	Evergreen Pear	15 gal.
Salix Babylonica	Weeping Willow	2.5" cal.
Taxodium Distichum	Bald Cypress	2.5" cal.
Ulmus Crassifolia	Cedar Elm	3" cal.

\* Tree seedlings five and one gallon trees are acceptable when planted as a supplement to larger trees, although not recommended for lawn areas.

3. Shrubs - Hedges, Screen

<u>Botanical Name</u>	<u>Common Name</u>	<u>Recommended Size</u> <u>Min*</u>
Abelia Grandiflora	Glossy Abelia	5 gal.
Ilex Crenata	Burford Holly	5 gal.
Ligustrum Texanum	Waxleaf Ligustrum	5 gal.
Oleander Nerium	Oleander	5 gal.
Myrica Corifera	Wax Myrtle	5 gal.
Photinia Fraseri	Fraser's Photinia	5 gal.
Photinia Serrulata	Chinese Photinia	5 gal.
Pittosporum Tobira	Pittosporum	5 gal.
Viburnum Japonicum	Japanese Viburnum	5 gal.
Viburnum Suspensum	Sandankwa Suspensum	5 gal.
Xyloasma Senticosa	Shiny Xyloasma	5 gal.

4. Shrubs - Accents, Massing

<u>Botanical Name</u>	<u>Common Name</u>	<u>Recommended Size</u> <u>Min*</u>
Cleyera Japonica	Japanese Cleyera	5 gal.
Cortaderia Selloana	Pampas Grass	5 gal.
Cycas Revoluta	Sago Cycad	15 gal.
Fatsia Japonica	Fatsia	1 gal.
Ilex Crenata "Burford"	Dwarf Burford Holly	1 gal.
Ilex Vomitoria Nana	Dwarf Yaupon Holly	1 gal.
Jasminum Mesnyi	Primrose Jasmine	1 gal.
Jasminum Humile	Italian Jasmine	1 gal.
Lagerstroemia Indica	Dwarf Crepe Myrtle 'Petite'	1 gal.
Michelia Fuscata	Banana Shrub	5 gal.
Nandina Domestica	Compact Nandina 'Compacta'	1 gal.
Pittosporum Tobira	Dwarf Pittosporum 'Wheeler'	1 gal.
Pyracantha Coccinea	Scarlet Firethorn	5 gal.
Raphiolepis Indica	Indian Hawthorn 'White'	1 gal.

5. Ground Covers - Plazas/Buildings

510-00-2351

<u>Botanical Name</u>	<u>Common Name</u>	<u>Recommended Size</u>
Ajuga Reptans	Ajuga	Min* 1 gal.
Apidistra Elatior	Cast Iron Plant	1 gal.
Asparagus Sprengerii	Sprengerii Fern	1 gal.
Cyrtomium Falatum	Holly Fern	1 gal.
Hedera Helix	English Ivy	1 gal.
Liriope Muscari	Big Blue Liriope	1 gal.
Liriope Grandiflora	Giant Liriope	1 gal.
Ophiopogon Japonica	Monkey Grass	1 gal.
Trachelospermum Asiaticum	Asian Jasmine	1 gal.

6. Ground Covers - Parking Lots

<u>Botanical Name</u>	<u>Common Name</u>	<u>Recommended Size</u>
Hedera Helix	English Ivy	Min* 1 gal.
Liriope Muscari	Big Blue Liriope	1 gal.
Liriope Grandiflora	Giant Liriope	1 gal.
Trachelospermum Asiaticum	Asian Jasmine	1 gal.

7. Vines - Buildings, Walls, Fences

<u>Botanical Name</u>	<u>Common Name</u>	<u>Recommended Size</u>
Ficus Pumila	Fig Ivy	Min* 1 gal.
Gelsemium Sempervivens	Carolina Jessamine	1 gal.
Lonicera Sempervirens	Coral Honeysuckle	1 gal.
Wisteria Megaspermum	Evergreen Wisteria	1 gal.
Wisteria Sinensis	Chinese Wisteria	1 gal.

8. Perennials - Plazas, Buildings

<u>Botanical Name</u>	<u>Common Name</u>	<u>Recommended Size</u>
Hemerocallis Species	Daylily	Min* 1 gal.
Moraea Iridiodes	Butterfly Iris	1 gal.
Iris 'Louisiana'	Louisiana Iris	1 gal.
Lantana Cammerra	Lantana	1 gal.

9. Grasses

<u>Botanical Name</u>	<u>Common Name</u>	<u>Recommended Size</u>
Stenotaphrum Secundatum	St. Augustine	Min* 3" plugs to solid sod
Cynodon Dactylon	Common Bermuda Grass	Seed/Hydro-mulch
Buchloe Dactyloides	Hybrid #609 Buffalo Grass	

\*1 Caliper: Caliper (trunk diameter) of all trees shall be measured at a point on the trunk six (6) inches above ground level up to four (4) inch caliper. Sizes four (4) inch caliper and larger, the measurement shall be at a point 12 inches above finish grade.

\*2 Container size shall conform to Grades and Standards Manual of the Texas Association of Nurserymen, where applicable.

## IV. Appendix B

510-00-2352

### A. Construction Controls

No permanent improvements shall be placed or constructed on the site until all plans related to the improvements have been reviewed and approved by the ARC. The builder/developer shall be responsible for any and all damages caused by his own forces, contractor and/or subcontractor, to the property adjacent to the site, including roadways. The builder/developer will also be responsible for heeding restrictions associated with any easements which may be located on the site.

#### 1. Tree Preservation

There will be no tree cutting or clearing until the applicant identifies the trees to be preserved and protected and/or relocated during the construction process. Every effort should be made to preserve the maximum number of trees on the site.

Existing trees to be preserved must be adequately protected from damage during construction. Those trees selected for preservation within an approved building site must be flagged and encircled with protective fencing. Fencing of the protected area must extend beyond the drip-line of the tree's branches to ensure reasonably successful protection. Clearing of underbrush in this area should not occur until completion of construction.

The following actions are prohibited within a designated tree protected area:

- Dumping backfill
- Excavating soil
- Felling trees
- Parking
- Driving construction equipment into or through the protected area
- Stacking or storing supplies and equipment
- Changing the site grading, thus allowing drainage to flow into or collect in the protected area
- Locating temporary buildings
- Dumping of paints, thinners, and other toxic materials

Where it is necessary to trench or bore for utility installation near protected trees, all possible care should be taken to avoid injury to tree roots. Excavations in areas where roots are two inches (2") or larger in diameter should be done by hand, tunneling under the roots.



510E00E2353

2. Site Clearing

No site clearing or construction may begin until the Builder/Developer has received written notification from the ARC stating construction may proceed.

B. Guidelines for Construction Activity

1. Equipment Access and Construction Parking

Access to each construction site should be kept to a minimum and be done in a manner to cause the least impact on existing landscaped or forested setbacks. Access will be limited to one (1) location from a public or common roadway. Location of the access must be approved by the ARC.

No construction worker's personal vehicle or construction equipment shall be parked in a landscaped setback, and as soon as it is possible, should not park on the street. A location on site shall be provided for wheel and equipment washdowns.

2. Temporary Structures and Fences

Temporary structures, portable offices, and other related facilities will be maintained in good repair and arranged in a compact and organized manner on the construction site. These facilities will be located so they are not obtrusive or unsightly from the road or adjacent properties. All temporary and portable structures will be removed within thirty (30) days from issuance of occupancy permit.

3. Construction Debris

Construction debris must be visually screened. All debris shall be removed from the site within fifteen (15) days after the occupancy permit is issued. If a debris pit is used during construction, protective fencing is required. Open burning of debris is prohibited.

After construction is completed, temporary barriers, surplus materials, trash, and debris must be removed from the site. All backfill must be cleared of building material, stone, and rubbish.

510E00-2354

4. Materials Storage

Construction materials are to be stored on site in an orderly manner that will not interfere with roadway traffic.

5. Erosion and Sediment Control

As stated in Section 1.C, step 2, each builder/developer is required to prepare and adhere to a Pollution Prevention Plan (PPP) which as a minimum addresses control of erosion offsite via vehicular traffic and/or stormwater runoff. Such erosion control measures may include use of silt fence, vegetative buffers, designated stabilized access pads, burlap bag barriers, inlet protection, daily street cleaning, etc.

6. Construction Hours

Sites adjacent to existing residential areas must observe hours of construction from 7:00 a.m. - 9:00 p.m.

C. Street Paving

Technical specifications shall conform to current City or applicable County minimum requirements. All paving shall be either concrete curb and gutter or asphalt and monolithic concrete curb and gutter. No open-ditch roadway drainage shall be permitted.

## V. Appendix C

### A. Definitions

Major Highway - A limited access street or highway, especially designed for through traffic, to which motorists and abutting property owners have only a restricted right of access. (Example: I-45, I-59 or U.S. 290)

Minor Highway - A street or highway, especially designed for local traffic, to which motorists and abutting property owners have unlimited right of access. (Example: FM 1960, State Highway 6).

Major Thoroughfare/Artery - A public street designed for fast, heavy traffic and intended to serve as a traffic artery of considerable length and continuity throughout the community and so designated on the latest edition of the Major Thoroughfare Plan.

Collector Street - A street which is not a designated major thoroughfare but provides access and circulation between major thoroughfares and local access and interior streets.

Local Street - Any public street not designated as a major thoroughfare, freeway or highway.

EXHIBIT "B" TO PROTECTIVE COVENANTS

510E00E2356

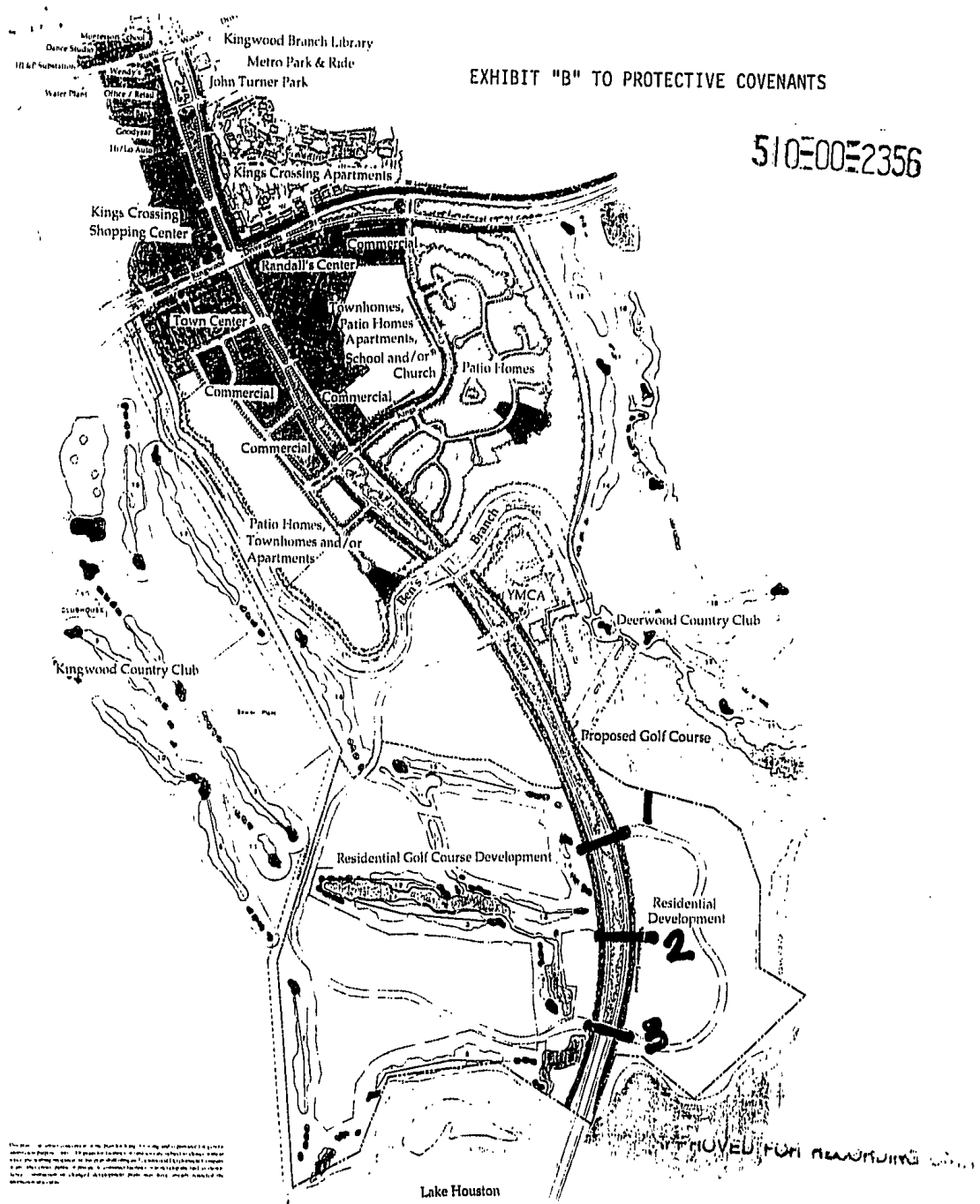

This plan is subject to the provisions of the Kings Crossing Master Plan and the Kings Crossing Protective Covenants. It is intended to be used in conjunction with the Kings Crossing Master Plan and the Kings Crossing Protective Covenants. It is not to be used as a separate document.

**KINGS CROSSING**  
Land Use Plan

*Gregory A. Brown*  
COUNTY ENGINEER

H.C.M.R.  
510-00-2357

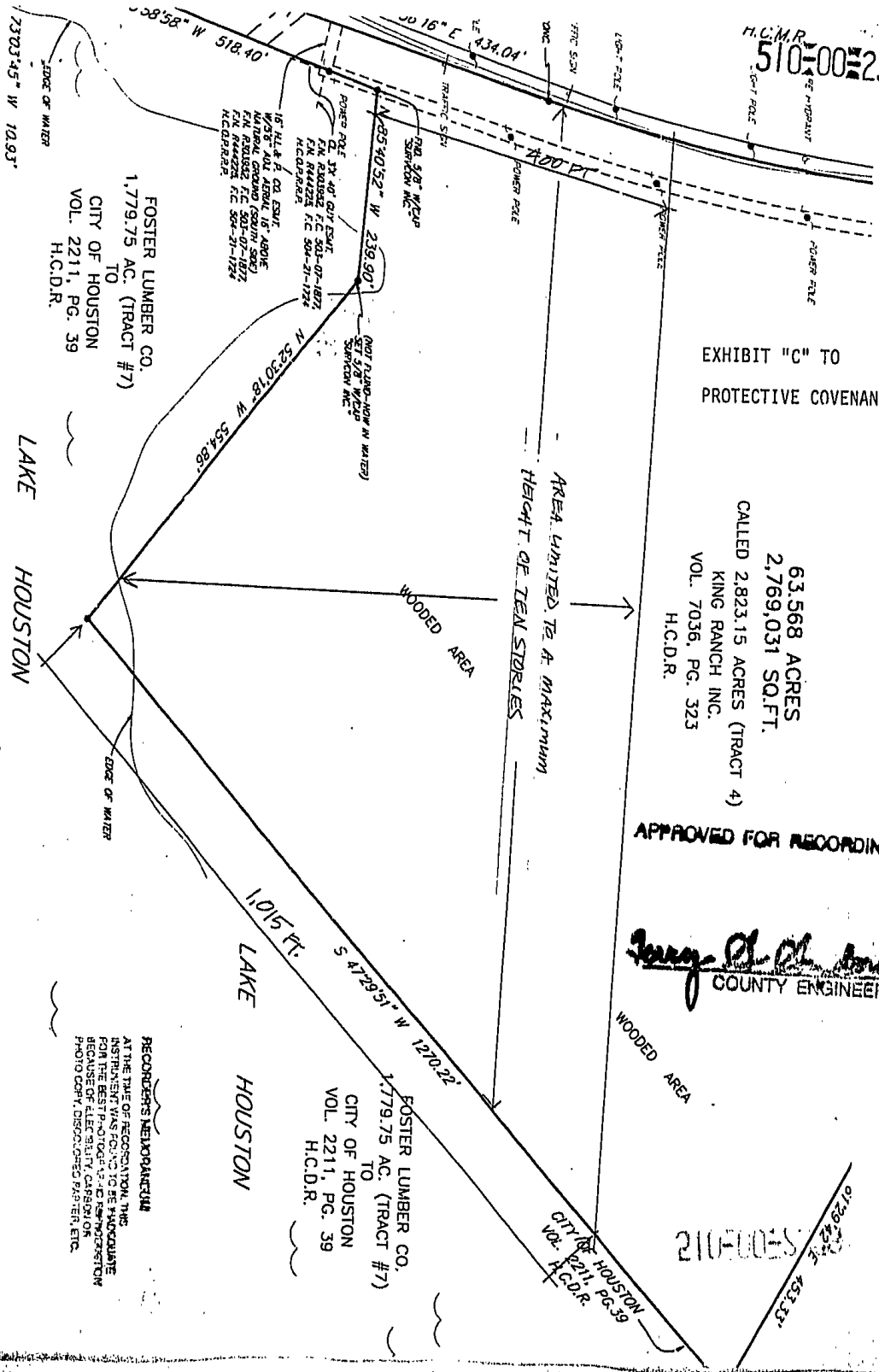

EXHIBIT "C" TO  
PROTECTIVE COVENANTS

63,568 ACRES  
2,769,031 SQ.FT.  
CALLED 2,823.15 ACRES (TRACT 4)  
KING RANCH INC.  
VOL. 7036, PG. 323  
H.C.D.R.

APPROVED FOR RECORDING ONLY

*Jerry D. Brown*  
COUNTY ENGINEER

FOSTER LUMBER CO.  
TO  
CITY OF HOUSTON  
VOL. 2211, PG. 39  
H.C.D.R.

157 H.L. & O. CO. SUBT.  
NATURAL GRASSLAND COUNTY 5062  
F.N. 1001022 F.C. 503-07-1872  
H.C.D.R. 221  
157 H.L. & O. CO. SUBT.  
NATURAL GRASSLAND COUNTY 5062  
F.N. 1001022 F.C. 504-07-1872  
H.C.D.R. 221

AREA LIMITED TO A MAXIMUM  
HEIGHT OF TEN STOREYS

FOSTER LUMBER CO.  
TO  
CITY OF HOUSTON  
VOL. 2211, PG. 39  
H.C.D.R.

RECORDED'S NEIGHBORHOOD  
AT THE TIME OF RECORDING THIS  
INSTRUMENT WAS FOUND TO BE  
FOR THE BEST PRACTICE AND  
BECAUSE OF ELECTRICITY, CARBON  
PHOTO COPY, DISCLOSED PARTNER, ETC.

CITY OF HOUSTON  
VOL. 2211, PG. 39  
H.C.D.R.

210-00-2357

0178  
453-33

510E00-2358

FILED

96 DEC -3 PM 2:47

*Beverly B. Kaufman*  
COUNTY CLERK  
HARRIS COUNTY, TEXAS

ANY PROVISION HEREIN WHICH RESTRICTS THE SALE, RENTAL OR USE OF THE DESCRIBED REAL PROPERTY BECAUSE OF COLOR OR RACE IS INVALID AND UNENFORCEABLE UNDER FEDERAL LAW THE STATE OF TEXAS COUNTY OF HARRIS I hereby certify that this instrument was FILED in File Number Sequence on the date and at the time stamped hereon by me; and was duly RECORDED in the Official Public Records of Real Property of Harris County, Texas on

DEC 3 1996



*Beverly B. Kaufman*  
COUNTY CLERK  
HARRIS COUNTY TEXAS

210E00-2329